

DD240XR

High-Speed Digital Demodulator

Installation and Operation Manual

MN-DD240XR
Revision E





Warranty Policy

The logo consists of the letters 'W' and 'P' in a bold, white, serif font, set against a solid black square background.

Comtech EF Data products are warranted against defects in material and workmanship for a period of two years from the date of shipment. During the warranty period, Comtech EF Data will, at its option, repair or replace products that prove to be defective.

For equipment under warranty, the owner is responsible for freight to Comtech EF Data and all related customs, taxes, tariffs, insurance, etc. Comtech EF Data is responsible for the freight charges only for return of the equipment from the factory to the owner. Comtech EF Data will return the equipment by the same method (i.e., Air, Express, Surface) as the equipment was sent to Comtech EF Data.

All equipment returned for warranty repair must have a valid RMA number issued prior to return and be marked clearly on the return packaging. Comtech EF Data strongly recommends all equipment be returned in its original packaging.

Comtech EF Data Corporation's obligations under this warranty are limited to repair or replacement of failed parts, and the return shipment to the buyer of the repaired or replaced parts.

Limitations of Warranty

The warranty does not apply to any part of a product that has been installed, altered, repaired, or misused in any way that, in the opinion of Comtech EF Data Corporation, would affect the reliability or detracts from the performance of any part of the product, or is damaged as the result of use in a way or with equipment that had not been previously approved by Comtech EF Data Corporation.

The warranty does not apply to any product or parts thereof where the serial number or the serial number of any of its parts has been altered, defaced, or removed.

The warranty does not cover damage or loss incurred in transportation of the product.

The warranty does not cover replacement or repair necessitated by loss or damage from any cause beyond the control of Comtech EF Data Corporation.

The warranty does not cover any labor involved in the removal and or reinstallation of warranted equipment or parts on site, or any labor required to diagnose the necessity for repair or replacement.

The warranty excludes any responsibility by Comtech EF Data Corporation for incidental or consequential damages arising from the use of the equipment or products, or for any inability to use them either separate from or in combination with any other equipment or products.

A fixed charge established for each product will be imposed for all equipment returned for warranty repair where Comtech EF Data Corporation cannot identify the cause of the reported failure.

Exclusive Remedies

Comtech EF Data Corporation's warranty, as stated is in lieu of all other warranties, expressed, implied, or statutory, including those of merchantability and fitness for a particular purpose. The buyer shall pass on to any purchaser, lessee, or other user of Comtech EF Data Corporation's products, the aforementioned warranty, and shall indemnify and hold harmless Comtech EF Data Corporation from any claims or liability of such purchaser, lessee, or user based upon allegations that the buyer, its agents, or employees have made additional warranties or representations as to product preference or use.

The remedies provided herein are the buyer's sole and exclusive remedies. Comtech EF Data shall not be liable for any direct, indirect, special, incidental, or consequential damages, whether based on contract, tort, or any other legal theory.

Warranty Repair Return Procedure

Before a warranty repair can be accomplished, a Repair Authorization must be received. It is at this time that Comtech EF Data will authorize the product or part to be returned to the Comtech EF Data facility or if field repair will be accomplished. The Repair Authorization may be requested in writing or by calling:

Comtech EF Data Corporation

2114 W 7th Street.
Tempe, Arizona 85281 (USA)
ATTN: Customer Support
Phone: (480) 333-2200
Fax: (480) 333-2540

Any product returned to Comtech EF Data for examination must be sent prepaid via the means of transportation indicated as acceptable to Comtech EF Data. Return Authorization Number must be clearly marked on the shipping label. Returned products or parts should be carefully packaged in the original container, if possible, and unless otherwise indicated, shipped to the above address.

Non-Warranty Repair

When a product is returned for any reason, Customer and its shipping agency shall be responsible for all damage resulting from improper packing and handling, and for loss in transit, notwithstanding any defect or nonconformity in the product. By returning a product, the owner grants Comtech EF Data permission to open and disassemble the product as required for evaluation. In all cases, Comtech EF Data has sole responsibility for determining the cause and nature of failure, and Comtech EF Data's determination with regard thereto shall be final.

Preface

P

This manual provides installation and operation information for the Radyne DD240XR Universal Satellite Modem. This is a technical document intended for use by engineers, technicians, and operators responsible for the operation and maintenance of the DD240XR.

Conventions

Whenever the information within this manual instructs the operator to press a pushbutton switch or keypad key on the Front Panel, the pushbutton or key label will be shown enclosed in "less than" (<) and "greater than" (>) brackets. For example, the Reset Alarms Pushbutton will be shown as <RESET ALARMS>, while a command that calls for the entry of a '7' followed by 'ENTER' Key will be represented as <7,ENTER>.

Cautions and Warnings



A caution icon indicates a hazardous situation that if not avoided, may result in minor or moderate injury. Caution may also be used to indicate other unsafe practices or risks of property damage.



A warning icon indicates a potentially hazardous situation that if not avoided, could result in death or serious injury.

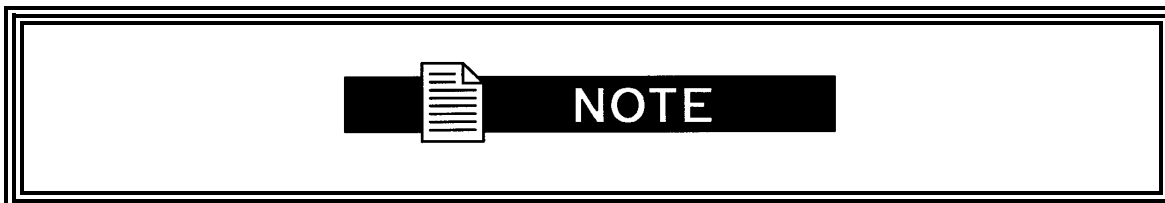

A note icon identifies information for the proper operation of your equipment, including helpful hints, shortcuts, or important reminders.

Trademarks

Product names mentioned in this manual may be trademarks or registered trademarks of their respective companies and are hereby acknowledged.

Copyright

©2009, Comtech EF Data This manual is proprietary to Comtech EF Data and is intended for the exclusive use of Comtech EF Data's customers. No part of this document may in whole or in part, be copied, reproduced, distributed, translated or reduced to any electronic or magnetic storage medium without the express written consent of a duly authorized officer of Comtech EF Data

Disclaimer

This manual has been thoroughly reviewed for accuracy. All statements, technical information, and recommendations contained herein and in any guides or related documents are believed reliable, but the accuracy and completeness thereof are not guaranteed or warranted, and they are not intended to be, nor should they be understood to be, representations or warranties concerning the products described. Comtech EF Data assumes no responsibility for use of any circuitry other than the circuitry employed in Comtech EF Data systems and equipment. Furthermore, since Comtech EF Data is constantly improving its products, reserves the right to make changes in the specifications of products, or in this manual at any time without notice and without obligation to notify any person of such changes.

Record of Revisions

Revision Level	Date	Reason for Change
1.0	4-12-06	Initial Release
1.1	11/10/06	Add DVBS2 BER info to manual Section 7.11.
1.2	7/24/07	Correct Front Panel Interface Options
1.3	11/22/07	Expanded DVBS2 Rates: 2 to 45Msps
D	2/19/09	Updated to Comtech. Corrected Inner Code Rates for DVB-S2-CCM for QPSK
E	3/13/09	Removed FEC Rates that product does not support

Comments or Suggestions Concerning this Manual

Comments or suggestions regarding the content and design of this manual are appreciated. To submit comments, please contact the Comtech EF Data Corporation Customer Service Department.

Table of Contents



Section 1 - Introduction	1-1
1.0 Description	1-1
Section 2 - Installation	2-1
2.0 Installation Requirements	2-1
2.1 Unpacking	2-2
2.2 Removal and Assembly	2-2
2.3 Mounting Considerations	2-2
2.4 Demodulator Checkout	2-3
2.4.1 Initial Power-Up	2-3
Section 3 - Theory of Operation	3-1
3.0 Theory of Operation	3-1
Section 4 - User Interfaces	4-1
4.0 User Interfaces	4-1
4.1 Front Panel User Interface	4-1
4.1.1 Front Panel LCD Display	4-2
4.1.2 Cursor Control Arrows	4-2
4.1.3 Front Panel Keypad	4-2
4.1.4 Front Panel LED Indicators	4-3
4.1.5 Parameter Setup	4-3
4.2 Front Panel Control Screen Menus	4-5
4.2.1 Main Menus	4-5
4.2.2 Demodulator Menu Options and Parameters	4-5
4.2.3 Interface Menu Options and Parameters	4-7
4.2.4 Monitor Menu Options and Parameters	4-12
4.2.5 Alarms Menu Options and Parameters	4-14
4.2.6 System Menu Options and Parameters	4-19
4.2.7 Test Menu Options and Parameters	4-26
4.3 Host Computer Remote Communications	4-28

4.3.1 Protocol Structure _____	4-28
4.3.2 Protocol Wrapper _____	4-28
4.3.3 Frame Description and Bus Handshaking _____	4-30
4.3.4 Global Response Operational Codes _____	4-31
4.3.5 Collision Avoidance _____	4-31
4.3.6 Software Compatibility _____	4-32
4.3.7 RLLP Summary _____	4-33
4.3.8 Remote Port Packet Structure _____	4-35
4.3.9 DD240XR Opcode Command Set _____	4-35
4.3.9.1 Demodulator Command Set _____	4-36
4.3.10 Detailed Command Descriptions _____	4-37
4.4 Ethernet Port User Interface _____	4-47
4.5 DD240XR Management Information Base (MIB) _____	4-48
4.6 Terminal Port User Interface _____	4-67
Section 5 - Electrical Interfaces	5-1
5.0 DD240XR Connections _____	5-1
5.1 AC Power _____	5-2
5.2 PCMCIA Interface (J1) _____	5-2
5.2.1 Feature Upgrade _____	5-2
5.2.2 Firmware Update _____	5-3
5.2.3 Custom Configuration Run Card _____	5-3
5.3 Ethernet Interface (J2) _____	5-3
5.4 Alarm Port (J3) _____	5-3
5.5 Remote Port (J4) _____	5-4
5.6 Terminal Port (J5) _____	5-4
5.7 RX RF IN (L-Band) (J6) _____	5-4
5.8 RX IF IN (J7) _____	5-4
5.9 J8 Ports _____	5-5
5.9.1 PARALLEL (ASI/DVB SPI or ASI/M2P Interfaces) _____	5-5
5.9.2 EXT CLK (HSSI and G.703 Interfaces Only) _____	5-6
5.9.3 PARALLEL/LVDS (ASI/M2P Interface Only) _____	5-6
5.10 HSSI Interface (J9) (HSSI Interface Only) _____	5-6
5.11 TX CLK (J10) (HSSI Interface Only) _____	5-6
5.12 J12 Ports _____	5-6

5.12.1 ASI (ASI/DVB SPI and ASI/M2P Interfaces Only) _____	5-6
5.12.2 G.703 OUT (G.703 Interface Only) _____	5-6
5.13 ECL Interface _____	5-7
5.13.1 ECL Balanced (J8) _____	5-7
5.13.2 ECL Unbalanced Data (J12) _____	5-7
5.13.3 ECL Unbalanced Clock (J13) _____	5-7
5.14 Ethernet Interface GiGi (J8) _____	5-8
5.14.1 Gigi Ethernet Data Interface, Additional Menus _____	5-8
Section 6 - Maintenance	6-1
6.0 Periodic Maintenance _____	6-1
Section 7 - Technical Specifications	7-1
7.0 Introduction _____	7-1
7.1 L-Band IF Specification _____	7-1
7.2 Optional 70/140 MHz Specification (includes L-Band) _____	7-1
7.3 Baseband Specification _____	7-1
7.3.1 DVB-S2-BS-NBC _____	7-2
7.4 Configuration Series DVB-S _____	7-2
7.5 Interface Types Available _____	7-3
7.6 Monitor and Control _____	7-3
7.7 Environmental _____	7-4
7.8 Physical _____	7-4
7.9 Options _____	7-4
7.10 BER Performance (DVB-S) _____	7-4
7.11 BER Performance (DVB-S2) Per EN 302-307 V1.1.1 _____	7-5
7.12 Data Rates (DVB-S) _____	7-5
7.13 Data Rates (DVB-S2) _____	7-7
Glossary	G-1



Introduction

1

1.0 Description

Radyne Corporation's DD240XR family of High-Speed Demodulators is the ideal choice to meet the exacting standards of high data-rate Video, Internet and Fiber Restoral Satellite Applications. The DD240XR supports both DVB-S and DVB-S2 Broadcast Services. The DVB-S supports QPSK, 8PSK and 16QAM applications with symbol rates up to 45 Msps and the DVB-S2 supports QPSK, 8PSK and 16APSK applications with symbol rates of 2 to 45 Msps. With a variety of data interfaces available, the DD240XR is configurable to meet high-speed satellite applications.

The powerful new onboard Monitor and Control (M&C) processor has the unique capability to download firmware and enhance features from a field-changeable PCMCIA card. Offering unprecedented flexibility, this feature represents a new level of Radyne Corporation's outstanding Customer Support. Additionally, features are added to the installed equipment base with extreme ease, allowing the equipment to expand with changes in service while lowering initial installation budgets.

The Demodulator offers a frequency-agile IF Input from 50 to 180 MHz (70/140), or 950 to 2150 MHz (L-Band) in 1Hz steps. Variable data rates for DVB-S (188 Mode) are from 2 Mbps to 145 Mbps and variable rates for DVB-S2 are from 1 Mbps to 160 Mbps.

Additional features include the choice of remotely interfacing through one of three onboard connections: 10 BaseT/100 Base-T Ethernet, RS-485, or RS-232. The familiar Radyne Front Panel (Figure 1-1) offers push-button control of all features and a backlit LCD display. Menus are specifically designed for ease of use and quick online operation as well as changes in all modulator configurations.

An optional 1:1 Redundancy Control Switch (RCS11) is available to provide the DD240XR with superior system reliability.



Figure 1-1. DD240XR



Installation

2

2.0 Installation Requirements

The DD240XR can be installed within any standard 19-inch equipment cabinet or rack, and requires one rack unit (RU) mounting space (1.75 inches) vertically and 17 inches of depth. Including cabling, a minimum of 20-inches of rack depth is required. The rear panel of the DD240 is designed to have power enter from the left and IF cabling enter from the right when viewed from the rear of the unit. Data and control cabling can enter from either side although they are closer to the center. The unit can be placed on a table or suitable surface if required.



There are no user-serviceable parts or configuration settings located inside the DD240XR chassis. There is a potential shock hazard internally at the power supply module. DO NOT open the DD240XR chassis under any circumstances.



Before initially applying power to the unit, it is a good idea to disconnect the transmit output from the operating ground station equipment. This is especially true if the current DD240XR configuration settings are unknown, where incorrect setting could disrupt existing communications traffic.

Earth connection is essential before connecting power to the DD240XR due to high leakage current.

*The DD240XR contains a Lithium Battery. **DANGER OF EXPLOSION** exists if the battery is incorrectly replaced. Replace only with the same or equivalent type recommended by the manufacturer. Dispose of used batteries in accordance with manufacturer's instructions.*

2.1 Unpacking

The DD240XR Demodulator was carefully packaged to avoid damage and should arrive complete with the following items for proper installation:

- DD240XR Unit
- PCMCIA Card (May be installed, depending upon configuration. If no card is installed, the unit has been factory configured)
- Power Cord, 6 foot with Applicable AC Connector
- Installation and Operation Manual.

2.2 Removal and Assembly

Carefully unpack the unit and ensure that all of the above items are in the carton. If the Prime AC power available at the installation site requires a different power cord/AC connector, then arrangements to receive the proper device will be necessary before proceeding with the installation.

The DD240XR modulator is shipped fully assembled. It does not require removal of the covers for any purpose in installation. The only replaceable assembly in the unit is the data interface and is not intended to be accomplished in the field. If the AC power connector is the wrong type for the installation, either the cable or the power connector should be replaced. The power supply itself is designed for universal application using from 100 to 240 VAC, 50 to 60 Hz, < 40 W.

2.3 Mounting Considerations

When mounted in an equipment rack, adequate ventilation must be provided. The ambient temperature in the rack should be between 10° and 35° C, and held constant for best equipment operation. The air available to the rack should be clean and relatively dry. The DD240XR units may be stacked one on top of the other up to a maximum of 10 consecutive units before providing a 1 RU space for airflow.

Do not mount the DD240XR in an unprotected outdoor location where there is direct contact with rain, snow, wind or sun. The DD240XR is designed for indoor applications only.

The only tools required for rack mounting the DD240XR is a set of four rack-mounting screws and an appropriate screwdriver. Rack mount brackets are an integral part of the cast front bezel of the unit and are not removable.

Shielded cables with the shield terminated to the conductive back shells are required in order to meet EMC directives. Cables with insulation flammability ratings of 94 VO or better are required in order to meet low voltage directives.

Earth connection is essential before connecting power to the DD240XR due to High Leakage Current.

2.4 Demodulator Checkout

The following descriptions assume that the DD240XR is installed in a suitable location with prime AC power and supporting equipment available.

2.4.1 Initial Power-Up



Before initial power up of the DD240XR, it is a good idea to disconnect the transmit output from the operating ground station equipment. This is especially true if the current demodulator configuration settings are unknown, where incorrect setting could disrupt existing communications traffic. New units from the factory are normally shipped in a default configuration which includes setting the transmit carrier off.

Turn the unit 'ON' by placing the rear panel switch (above the power entry connector) to the 'ON' position. Upon initial and subsequent power-ups, the DD240XR microprocessor will test itself and several of its components before beginning its main Monitor/Control program. These power-up diagnostics show no results if successful. If a failure is detected, the Fault LED is illuminated.

The initial field checkout of the DD240XR can be accomplished from the Front Panel, Terminal Port, Remote Port, or Ethernet Port.



Theory of Operation

3

3.0 Theory of Operation

The basic theory of operation for each platform is similar. The DD240XR is capable of supporting L-band from 950-2150 MHz and can be upgraded to include IF frequencies of 50-180 MHz in the same package. If the unit is configured to receive analog signal in the IF band of 50-180 MHz, the signal is converted to L-band. The L-band signal is then tuned and digitally demodulated. The incoming I&Q symbols are then filtered decoded, and mapped to data bits. The network specification selected will determine if the data stream supports DVB-S or DVB-S2 formats.

The DVB-S Network specification complies with both EN300-421 and EN301-210 ETSI specifications. EN300-421 supports QPSK demodulation and EN301-210 supports higher demodulation rates of 8PSK and 16QAM. The resulting data stream is FEC decoded by the Viterbi (K=7) inner convolutional/trellis decoder, de-interleaved and further FEC decoded by the outer Reed Solomon 204/188 decoder.

The DVB-S2 Network specification complies with the next generation DVB open standard supported by EN302-307. At the core of this standard is a powerful Bose-Chaudhuri-Hocquenghem BCH decoding and concatenated Low-Density Parity Check (LDPC). The DD240XR only supports normative features identified by the DVB-S2 Broadcast services. The Broadcast Services mode of operation supports Constant Coding and modulation (CCM) system and single transport streams. Operating in this mode allow for a variety of FEC rates to be used with QPSK, 8PSK and 16APSK modulation schemes.

The decoded data is then sent through a deframer to provide terrestrial data that is either unframed, 188 byte DVB format or 204 byte DVB format. Based on the type of terrestrial interface installed, the data stream is re-clocked through an optional Doppler buffer, serialized and converted through the appropriate physical layer interface. A functional block diagram is shown in Figure 3-1.

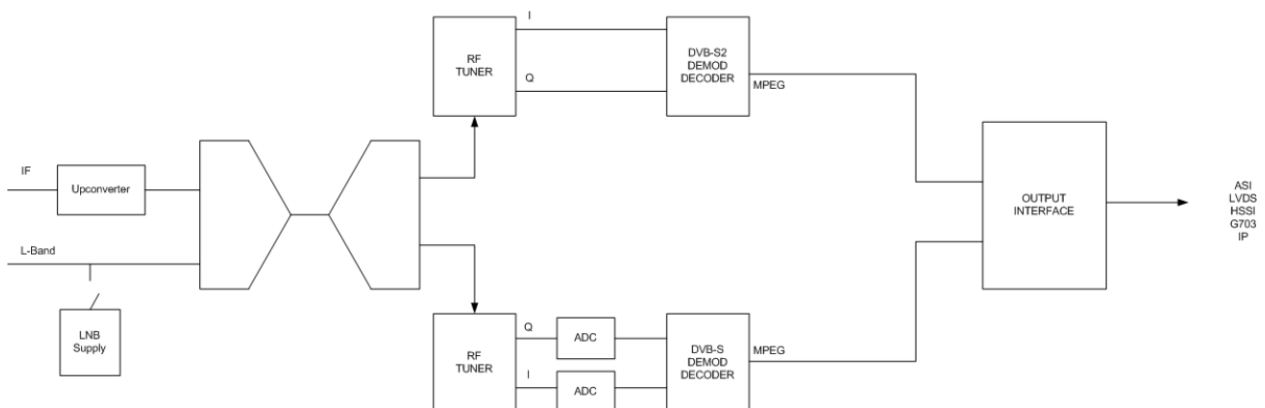

Figure 3-1. Functional Block Diagram



User Interfaces

4

4.0 User Interfaces

There are four User Interfaces available for the DD240 family of products. These are:

- Front Panel
- Remote Port
- Ethernet Port
- Terminal

4.1 Front Panel User Interface

The Front Panel of the DD240XR allows for complete control and monitor of all DD240XR parameters and functions via a keypad, LCD display and status LEDs.

The Front Panel layout is shown in Figure 4–1, showing the location and labeling of the Front Panel. The Front Panel is divided into four functional areas: the LCD Front Panel Display, the Cursor Control Arrows, the Numeric Keypad and the LED Indicators, each described below in Table 4-1.

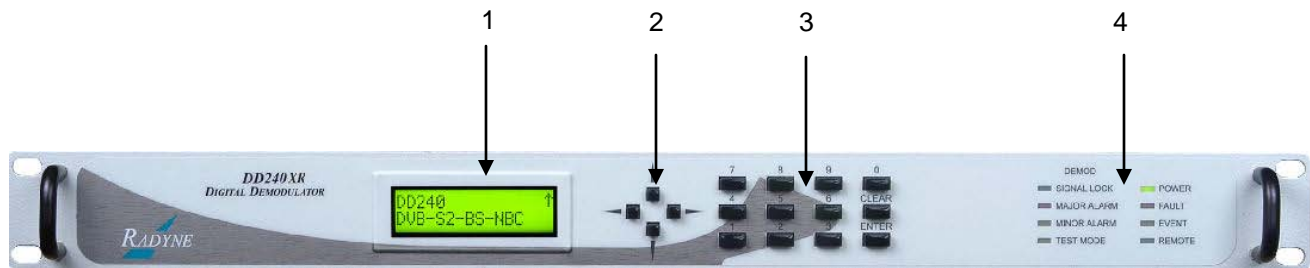

Figure 4-1. DD240XR Front Panel

Table 4-1.		
Item Number	Description	Function
1	Front Panel LCD Display	Displays DD240XR Operating Parameters and Configuration Data.
2	Cursor Control Arrows	Controls the up, down, right and left motion of the cursor in the LCD Display Window.
3	Numeric Keypad	Allows the entry of numeric data and Clear and Enter Function Keys.
4	Front Panel LED Indicators	See Section 4.1.4 below for an itemized description of these LEDs.

4.1.1 Front Panel LCD Display

The Front Panel display is a 2 line by 16-character LCD display. The display is lighted and the brightness can be set to increase when the Front Panel is currently in use. The LCD display automatically dims after a period of inactivity. The display has two distinct areas showing current information. The upper area shows the current parameter being monitored, such as 'Frequency' or 'Data Rate'. The lower line shows the current value of that parameter. The LCD display is a single entry window into the large matrix of parameters that can be monitored and set from the Front Panel.

4.1.2 Cursor Control Arrows

The 'Cursor' or 'Arrow' Keys (↑), (↓), (→), (←), are used to navigate the parameter currently being monitored or controlled. Table 4-2 describes the key functions available at the Front Panel.

Table 4-2.							
Edit Mode Key Functions (Front Panel Only)							
Parameter Type	0 – 9	↑	↓	←	→	'Clear' & ←	'Clear' & →
Fixed Point Decimal	Changes Digit	Toggles ± (If Signed)	Toggles ± (If Signed)	Moves Cursor 1 Position Left	Moves Cursor 1 Position Right	N/A	N/A
Unsigned Hexadecimal	Changes Digit	Increments Digit Value	Decrements Digit Value	Moves Cursor 1 Position Left	Moves Cursor 1 Position Right	N/A	N/A
Enumerated	N/A	Previous Value in List	Next Value in List	N/A	N/A	N/A	N/A
Date/ Time	Changes Digit	N/A	N/A	Moves Cursor 1 Position Left	Moves Cursor 1 Position Right	N/A	N/A
IP Address	Changes Digit	Increments Digit Value	Decrements Digit Value	Moves Cursor 1 Position Left	Moves Cursor 1 Position Right	N/A	N/A
Text Strings	Changes Character	Increments Character Value	Decrements Character Value	Moves Cursor 1 Position Left	Moves Cursor 1 Position Right	Clears to Left of Cursor Inclusive	Clears to Right of Cursor Inclusive

4.1.3 Front Panel Keypad

The Front Panel Keypad consists of a 10-key numeric entry with 2 additional keys for the 'Enter' and 'Clear' functions.

4.1.4 Front Panel LED Indicators

Eight LEDs on the DD240XR Front Panel (Refer to Table 4-3) indicate the status of the DD240XR's operation. The LED colors maintain a consistent meaning. Green signifies that the indication is appropriate for normal operation. Yellow means that there is a condition not proper for normal operation, and Red indicates a fault condition that will result in lost communications.

Table 4-3.		
LED	Color	Function
Carrier Lock	Green	Indicates the DD240XR Demodulator and Decoder are locked.
Major Alarm	Red	Indicates that the receive direction has failed, losing traffic.
Minor Alarm	Yellow	Indicates a receive warning condition exists.
Test Mode	Yellow	Indicates the demodulator is involved in current test mode activity.
Power	Green	Indicates the DD240XR unit is currently powered up.
Fault	Red	Indicates a common fault exists such as power out of spec.
Event	Yellow	Indicates that the events have been logged into the event buffer.
Remote	Green	Indicates that the unit is set to respond to the remote control or terminal input.

4.1.5 Parameter Setup

The four arrow keys (↑), (↓), (→), (←), to the right of the LCD display are used to navigate the menu tree and select the parameter to be set. After arriving at a parameter that needs to be modified, depress <ENTER>. The first space of the modifiable parameter highlights (blinks) and is ready for a new parameter to be entered. After entering the new parameter using the keypad (Refer to Figure 4-3), depress <ENTER> to lock in the new parameter. If a change needs to be made prior to pressing <ENTER>, depress <CLEAR> and the display defaults back to the original parameter. Depress <ENTER> again and re-enter the new parameters followed by <ENTER>.

Following a valid input, the DD240XR will place the new setting into the nonvolatile SRAM making it available immediately and available the next time the unit is powered-up.

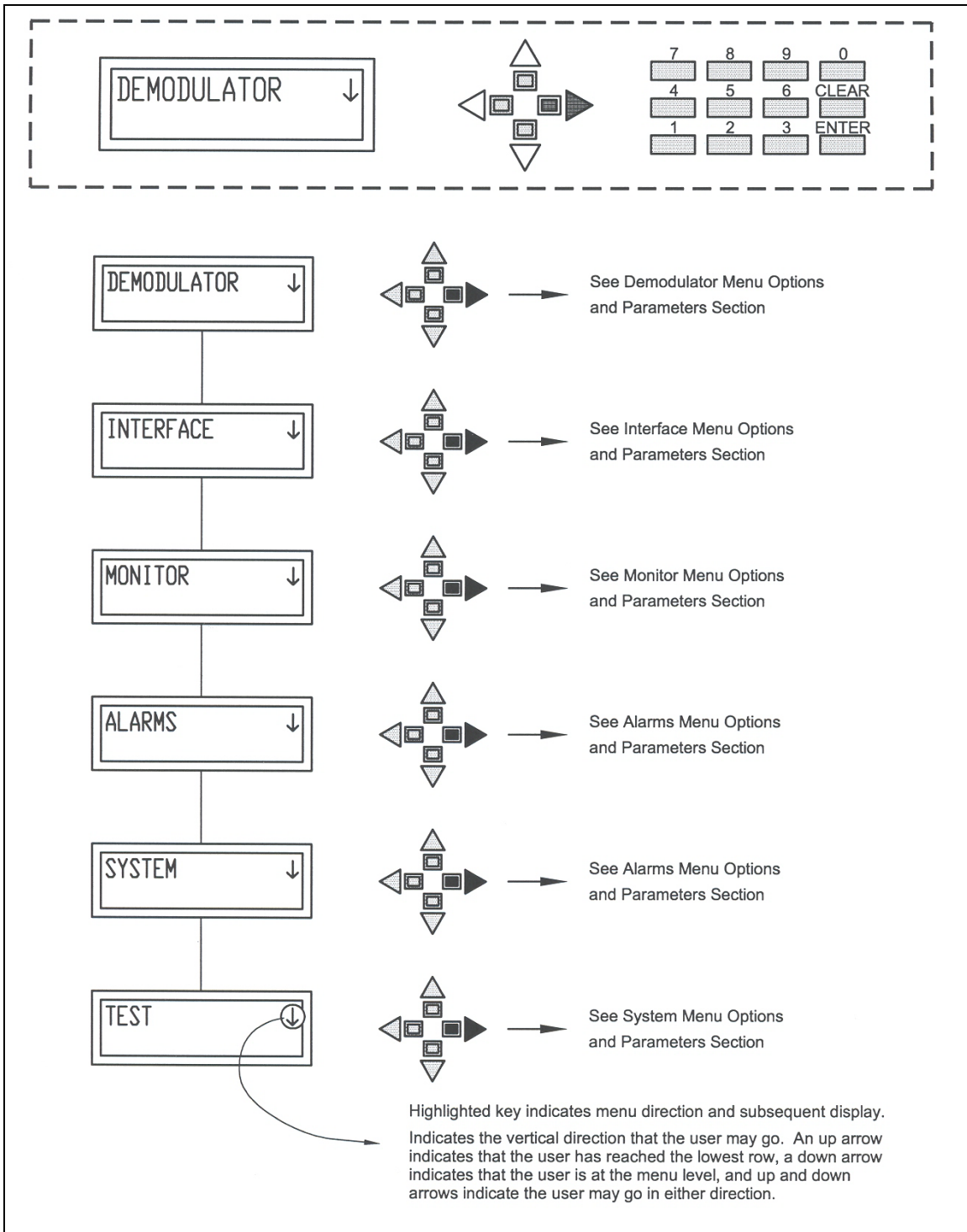

Figure 4-2. DD240XR Main Programming Menu

Note: If at any time the user wishes to abort the changes being made, depress <CLEAR> to begin again.

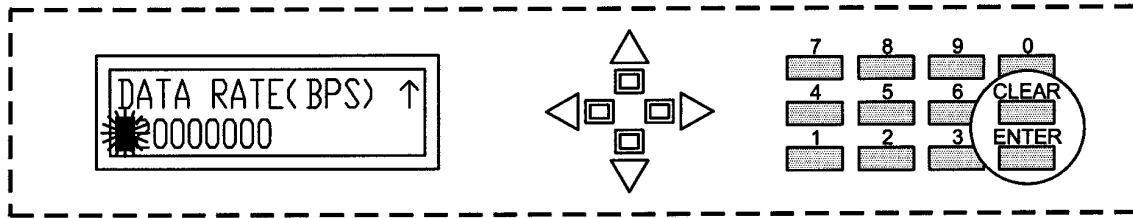

Figure 4-3. Entering New Parameters

4.2 Front Panel Control Screen Menus

The DD240XR Front Panel Control Screens are broken down into sections under several Main Menus.

4.2.1 Main Menus

Demodulator

Interface

Monitor

Alarms

System

Test

4.2.2 Demodulator Menu Options and Parameters

NETWORK SPEC: {DVBS, DVB-S2-BS-NBC}

FREQUENCY (MHz): {NNNN.NNNNNN}
Carrier Frequency – Enter in 1 Hz increments where NNNN.NNNNNN is the frequency in MHz.

Select a carrier with 1 Hz steps.

MODULATION: DVB-S: {8PSK, 16QAM},
DVB-S2 {QPSK, 8PSK, 16APSK}
Displays the Modulation Type

INNER FEC RATE: DVB-S QPSK: 1/2, 2/3, 3/4, 5/6, 7/8
DVB-S 8PSK: 2/3, 5/6, 8/9
DVB-S 16QAM: 3/4, 7/8

DVB-S2 QPSK: 1/2, 2/3, 3/5, 3/4, 4/5, 5/6, 8/9, 9/10
DVB-S2 8PSK: 2/3, 3/5, 3/4, 5/6, 8/9, 9/10
DVB-S2 16APSK: 2/3, 3/4, 4/5, 5/6, 8/9, 9/10
Note: 9/10 only available with normal FEC frames

SAT FRAMING**FECFRAME**

Select **NORMAL** n_ldpc = 64,800 or
SHORT n_ldpc = 16,200

DATA RATE (bps):**Terrestrial Data Rate:**

Enter in 1 bps increments from 2,000,000 to 160,000,000 BPS.

SYMB RATE (sps):**Output Symbol Rate:**

Enter in 1 sps increments from 2,000,000 to 45,000,000 sps.

SPECTRUM:**{AUTO DETECT}**

This is the commanded spectrum detection. Select **NORMAL** or **INVERTED**. This display is not user selectable for DVBS 8PSK or 16QAM, where it is fixed as **AUTO DETECT**.

ROLL OFF:

DVB-S: **{0.20, 0.35}** for QPSK/8PSK/16QAM.
DVB-S2 **{20, .25, .35}** for QPSK/8PSK/16APSK

PILOT SYMBOLS:**{ON, OFF}**

Used to enable pilot symbol for DVB-S2 only

GOLD SEQ N:**{012345}**

Gold code sequence number for DVB-S2 only

LAST RATE CTRL:**{SYMBOL RATE, DATA RATE, AUTO}**

Indicates the rate (symbol or data) which is maintained when associated parameters (i.e. Modulation, Inner FEC Code Rate, Terr Framing) are changed. For example, if the Last Rate Control is set to "Symbol Rate" and the modulation is subsequently changed, the system will attempt to maintain the same symbol rate by adjusting the data rate. If the Last Rate Control is set to "Data Rate" and the modulation is subsequently changed, the system will attempt to maintain the same data rate by adjusting the symbol rate.

The “Auto” Setting of Last Rate Control causes the last explicitly changed rate (symbol or data) to be maintained when associated parameters are changed. For example, if the last rate control is set to “Auto” and the Data Rate is subsequently explicitly changed, any subsequent changes to Modulation or Inner FEC Rate would cause the symbol rate to be adjusted in order to maintain the Data Rate.

ACQ RANGE:**{Variable in one Hz steps}**

Acquisition Range – Allows the user to set the carrier acquisition sweep range. Sweep rate range changes based on Data rate and FEC rate.

LNB POWER:**{ON, OFF}**

Used to enable the LNB 18V DC Output to J6.

EBNO FLOOR (dB):**{1, 15}**

This screen is used for setting the level at which an Eb/No Alarm should be indicated. This will occur when the measured Eb/No value is less than the floor level and an Event and Alarm will be generated.

4.2.3 Interface Menu Options and Parameters

INTERFACE TYPE:

{ASI, Advanced ASI, HSSI, RS-442 Serial, M2P Parallel, DVB Parallel, G.703 STS1, G.703.E3, G.703.T3, ECL BAL/UNBAL, ETHERNET GIGE}

Allows the user to enter the Terrestrial Interface type.



Only the Interface types that are installed may be selected.



When a G.703 interface is selected the data rate and symbol rates are dictated by the interface.

TERR FRAMING: {None, DVB 188, DVB 204}
 Terrestrial Framing – Allows the user to choose framing packet. None equals 187 framing.



When configured with an Ethernet Interface, TERR FRAMING is always 188 framing.

TERR STREAMING: {Byte Output, Packet Output}
 Only applies when ASI interface is installed

DATA POLARITY: {NORMAL, INVERTED}
 This allows user to invert the data.

CLOCK POLARITY: {NORMAL, INVERTED}
(This menu is not displayed when ASI interface is installed)
 Rx Clock Polarity – Allows the user to specify the clock sense. This should be set the same as the Modulator Source.

BUFF CLOCK SRC: {RX SAT, EXC DIR, EXC REF PLL}
 When G703 Interface is installed the Buffer Clock Source options are below are available. All other interfaces may display RX SAT.

RX SAT - Clock is recovered from the satellite data transmission.
 EXC DIR – Clock is provided by an external clock source. Not all terrestrial interfaces include a Doppler buffer.
 EXC REF PLL – Clock is provided by an external clock source and passed through a phase locked loop. Not all terrestrial interfaces include a Doppler buffer.



RX SAT Clock is the standard clock with most interfaces. External clocks are available only if the interface is buffer capable. If the interface is not buffer capable, the EXC Options (BUFF CLK SRC, EXC REF CLOCK, RX BUFFER SIZE, and RX BUFFER RESET) will not be displayed.

- EXC REF CLOCK:** **{1.000, 1.544, 2.000, 2.048, 5.000, 6.312, 8.448, 10.000 MHz} (This menu not displayed when Ethernet interface is installed)**
 Rx Reference Clock Rate
 This menu allows the user to specify the reference clock rate. The rates are the most commonly used and include T1, E1, T2 and E2 references. Not all terrestrial interfaces include a Doppler buffer.
- RX BUFFER SIZE:** Allows the user to specify the buffer depth. Enter in 1 msec increments from 00 to 64. A value of 0 will disable, bypass, buffering and the demodulator will then use the RX SAT as the clock source. Not all terrestrial interfaces include a Doppler buffer.
- TERR ETHERNET:** This menu is displayed when Ethernet interface is installed. This interface supports MPEG over IP traffic. This menu can be configured to support Ethernet Bridge option or PRO MPEG COP3 option. Each option supports different menu structures. The following items are available under the Terrestrial Ethernet menu:
- PROG ETH FLASH:** **{PRESS CLEAR}**
 When Bridge option is selected, the PROG ETH FLASH menu is the only menu displayed. The PROG ETH FLASH allows the user to select the desired Ethernet protocol option. The protocols supported by the DD240XR are Ethernet Bridge or Pro MPEG COP 3. If unit is configured for Bridge option, the user can activate the PRO MPEG COP3 option by pressing the <Down Arrow>. Once COP3 is reflected on the front panel, press the <Clear> button to activate the option. The front panel will display a sequence process indicating that the flash is being Erased, Programmed, and Verified. At the end of sequence the final status will be displayed as either Successful or Unsuccessful.

THE FOLLOWING MENUS ARE DISPLAYED WHEN THE TERRESTRIAL ETHERNET INTERFACE IS CONFIGURED FOR PRO MPEG COP 3.

- TERR MAC ADDR:** **{0123456789AB}**
 This menu displays the MAC addresses of the Ethernet Data Interface card. Entering any non-zero value in this field will cause the EDI to use the entered value as its MAC address.
 Entering a value of all zeros will cause the Ethernet Data Interface to revert back to its original MAC address.

MODE SELECTION:

UDP PACKETS: The Demodulator outputs seven MPEG packets encapsulated in UDP datagram.

COP3 RTP: The Demodulator outputs seven MPEG packets encapsulated in a COP3 compliant RTP datagram.

COP3 RTP FEC: The Demodulator outputs COP3 compliant column FEC packets in addition to the RTP datagram.

IP ADDR:

{XXX.XXX.XXX.XXX}

This is the IP address to be used by the Ethernet Data Interface. This will be the source IP address for all Ethernet traffic generated by this interface.

UDP PORT:

{XXXXX}

This is the source UDP port to be used by the Ethernet Data Interface.

DEST IP ADDR:

{XXX.XXX.XXX.XXX}

This is the destination IP address that the Ethernet Data Interface will send all Ethernet data traffic to.

DEST UDP PORT:

{XXXXX}

This is the destination UDP port that the Ethernet Data Interface will send all MPEG traffic to.

***Unicast Destination IP Addresses***

When the destination address is a Unicast address (000.000.000.000 thru 223.255.255.255) the Ethernet Data Interface will use an ARP Request to determine the Destination MAC address to which the data will be sent. This could be the MAC address of the final destination or the MAC address of the first router through which this data will pass. The Ethernet Data Interface will not output any data until it receives an ARP Reply to its ARP Request.



NOTE

Multicast Destination IP Addresses

When the destination address is a Multicast address (224.000.000.000 thru 255.255.255.255) the Ethernet Data Interface will construct the appropriate Destination Multicast MAC address based upon the Destination Multicast IP Address. The Ethernet Data Interface will then transmit multicast data packets to the destination without performing any other handshaking or IGMP message processing.

BLOCK ALIGNED:	<p>{YES or NO} This menu is only visible when COP 3 RTP FEC is selected. Yes: selects block aligned Column FEC. No: selects non-block aligned Column FEC. Each column is offset by 1, as illustrated in Informative Annex A of COP 3 release 2.</p>
FEC COLUMN L	<p>{X} This menu is only visible when COP 3 RTP FEC is selected. This selects the number of columns used by the FEC calculation.</p>
FEC COLUMN D	<p>{X} This menu is only visible when COP 3 RTP FEC is selected. This selects the number of rows used by the FEC calculation.</p>



NOTE

Constraints on L and D values

L and D have the following constraints

$$\begin{aligned}
 4 &\leq L \leq 20 \\
 4 &\leq D \leq 20 \\
 L * D &\leq 100
 \end{aligned}$$

PROG ETH FLASH:**{PRESS CLEAR}**

The PROG ETH FLASH allows the user to select the desired Ethernet protocol. The protocol options supported by the DD240XR are Pro MPEG COP 3 or Bridge. If unit is configured for COP 3, the user can activate Bridge option by pressing the <Down Arrow>. Once Bridge is reflected on the front panel, press the <Clear> button to activate the Bridge protocol. The front panel will display a sequence process indicating that the flash is being Erased, Programmed, and Verified. At the end of sequence the final status will be displayed as either Successful or Unsuccessful.

4.2.4 Monitor Menu Options and Parameters**EVENTS:****Event Buff:**

Display/Clear logged events and faults. Depressing <ENTER> on the Front Panel allows the user to view logged events. Depressing <ENTER> again allows normal menu traversal to continue.

ERASE EVENTS:**PRESS CLEAR**

Clear all logged events and faults from the event buffer.

INPUT LVL (dBm):**{0 - 100}**

This screen is used to display the current signal level being detected by the demodulator.

EBNO (dB):**{XXXNN.NN}**

NN.NN = the current Eb/No in dB. XXX may be one of the following:

- = The Eb/No is within the valid range.
- > The Eb/No is above the valid range. The displayed value is irrelevant and is accompanied by an Alarm LED.
- < The Eb/No is below the valid range. The displayed value is irrelevant and is accompanied by an Alarm LED.

“???” The Eb/No is invalid. The displayed value is irrelevant and is accompanied by an Alarm LED.

BER AFTER OFEC:**DVBS only**

{ 1.5×10^{-15} , 3.7×10^{-2} (in QPSK)}

{ 7.7×10^{-16} , 1.9×10^{-2} (in 8PSK)}

{ 7.7×10^{-16} , 1.9×10^{-2} (in 16QAM)}

This screen displays the estimated Bit Error Rate (BER) after decoding.

MPEG PER:**DVBS2 only**

This screen displays the ratio of mpeg packets with CRC errors to mpeg packets with no errors. No CRC errors = 0, every packet with a CRC error = 1.

FREQ OFFSET (Hz):**{-2.5 MHz, +2.5 MHz}**

This screen displays the actual carrier frequency offset from the programmed frequency.

SYMB RATE OFFSET (Hz):**{-1000 Hz, 1000 Hz}**

This screen displays the symbol rate recovered as an offset from the programmed symbol rate.

SPECTRUM:**{NORMAL, INVERTED}**

This is the spectrum detection as detected by the internal carrier subsystem.

RX BUFFER LEVEL:

This screen displays the buffer level in percent full.
Displayed in buffer capable units only

RX BUFFER RESET:

Allows the user to re-center, and therefore, reset the buffer. Pressing the <ENTER> button will force a re-centering and will result in a momentary loss of data or frame slip. Not all terrestrial interfaces include a Doppler buffer.

+5V SUPPLY:

Display the currently measured +5 VDC power supply.

+12V SUPPLY:

Display the currently measured +12 VDC power supply.

-12V SUPPLY:

Display the currently measured -12 VDC power supply.
Only on units with a HSSI or ECL BAL/UNBAL Terrestrial Interface installed.

+24V SUPPLY:

Display the currently measured +24 VDC power supply.

MONITOR - The following new items are available under the Monitor menu

LINK STATUS:**{1 GIG FULL, 100 MEG FULL, NO LINK}**

This menu displays the current terrestrial link status and rate at which the Ethernet Data Interface has established a physical connection.

1 GIG FULL - One Gigabit Full Duplex (1000BaseT)
100 MEG FULL 100 Megabits Full Duplex (100BaseT)
NO LINK - No connection.

TOTAL PACKETS:**{0123456789}**

This menu displays the total number of data packets that have been output by the Ethernet Data Interface. This is either the number of UDP packets in UDP mode, or the number of RTP packets in COP3 RTP and COP3 RTP FEC mode.

FEC PACKETS:**{0123456789}**

This menu is only visible when COP 3 RTP FEC is selected.

This menu displays the total number of FEC packets that have been output by the Ethernet Data Interface in COP3 RTP FEC mode.

CLEAR STATUS: (ENTER)

Pressing Enter will reset the Total Packet and FEC Packet counters.

4.2.5 Alarms Menu Options and Parameters

CURRENT ALARM (Menu): Displays Current Alarm Status.

RX MAJOR (Menu):

	<u>Status</u>	<u>Edit Table</u>
SIGNAL LOCK:	{Pass/Fail, Unmasked/Masked}	This screen is used to enable/disable alarms when the Carrier Lock is not present.
SYNTH PLL:	{Pass/Fail, Unmasked/Masked}	This screen is used to enable/disable alarms when the On-Board Phase-Locked Loop cannot lock to the input signal.
INPUT LEVEL:	{Pass/Fail, Unmasked/Masked}	This screen is used to enable/disable alarms when the Input Level is too low.
CLOCK ACTIVITY:	{Pass/Fail, Unmasked/Masked}	
CARRIER COMM:	{Pass/Fail, Unmasked/Masked}	This screen is used to enable/disable alarms when communications have failed with the Internal Carrier Control Subsystem.
DEMOD COMM:	{Pass/Fail, Unmasked/Masked}	This screen is used to enable/disable alarms when communications have failed with the Internal Demodulation Control Subsystem.
<u>FPGA CONFIG:</u>	{Pass/Fail, Unmasked/Masked}	
DJIT CFG:	{Pass/Fail}	This screen is used to enable/disable alarms when DJIT FPGA has failed to configure appropriately.
TERR INTFC CFG:	{Pass/Fail}	This screen is used to enable/disable alarms when the Terrestrial Card FPGA has failed to configure appropriately.

RX MINOR (Menu):



NOTE

DD240XR only displays buffer status and alarm prompts for terrestrial interfaces that support Doppler buffering.

DATA ACTIVITY:	{Pass/Fail, Unmasked/Masked} This screen is used to enable/disable alarms when data is not detected in the signal.
BUFF UNDERFLOW:	{Pass/Fail, Unmasked/Masked} This screen is used to enable/disable the alarm which occurs when the signal buffer completely empties and resets. This menu is only available if the terrestrial interface is buffer capable.
BUFF NEAR EMPTY:	{Pass/Fail, Unmasked/Masked} This screen is used to enable/disable the alarm which occurs when the signal buffer reaches a near empty value of 10%. This menu is only available if the terrestrial interface is buffer capable.
BUFF NEAR FULL:	{Pass/Fail, Unmasked/Masked} This screen is used to enable/disable the alarm which occurs when the signal buffer reaches a near full value of 90%. This menu is only available if the terrestrial interface is buffer capable.
BUFF OVERFLOW:	{Pass/Fail, Unmasked/Masked} This screen is used to enable/disable the alarm which occurs when the signal buffer completely fills and resets. This menu is only available if the terrestrial interface is buffer capable.
EXC CLOCK:	{Pass/Fail, Unmasked/Masked} This screen is used to enable/disable the alarm which occurs when the signal buffer external clock is no longer detected. This menu is only available if the terrestrial interface is buffer capable.
EXC PLL LOCK:	{Pass/Fail, Unmasked/Masked} This screen is used to enable/disable the alarm which occurs when the signal buffer external clock being routed to the terrestrial interface PLL is no longer detected. This menu is only available if the terrestrial interface is buffer capable.
DEMOD LOCK:	{Pass/Fail, Unmasked/Masked}

This screen is used to enable/disable alarms when the demodulator has lost lock.

IFEC LOCK:	{Pass/Fail, Unmasked/Masked} This screen is used to enable/disable alarms when the Inner Forward Error Correction has encountered too many errors.
OFEC LOCK:	{Pass/Fail, Unmasked/Masked} This screen is used to enable/disable alarms when the Outer Forward Error Correction has encountered too many errors.
FRAME SYNC:	{Pass/Fail, Unmasked/Masked} This screen is used to enable/disable alarms when the DVB Frame Sync Byte (0 x 47) is not recovered from the Input Stream.
EBNO:	{Pass/Fail, Unmasked/Masked} This screen is used to enable/disable alarms when the Eb/No value has fallen below the floor alarm value.
IP DEST ADDR	{Unmasked/Masked}} Fail indicates the EDI has not received an ARP reply to its ARP requests and thus has not been able to resolve the destination MAC address.
ETH LINK	{Unmasked/Masked} Fail indicates that the Ethernet Data Interface has not been able to establish a valid physical connection on its Ethernet data port.
<u>COMMON (Menu):</u>	
+5V SUPPLY:	{Pass/Fail, Unmasked/Masked} This screen is used to enable/disable alarms when the +5 V Power Supply has drifted outside specifications.
+12V SUPPLY:	{Pass/Fail, Unmasked/Masked} This screen is used to enable/disable alarms when the +12 V Power Supply has drifted outside specifications.
-12V SUPPLY:	{Pass/Fail, Unmasked/Masked} This screen is used to enable/disable alarms when the -12 V Power Supply has drifted outside specifications. Only on units with a HSSI or ECL BAL/UNBAL Terrestrial Interface installed.
+24V SUPPLY:	{Pass/Fail, Unmasked/Masked} This screen is used to enable/disable alarms when the +24 V Power Supply has drifted outside specifications.
DEMOD HW FAULT:	{Pass/Fail, Unmasked/Masked}

LATCHED ALARMS (Menu):

This menu duplicates the Current Alarm Menu, but displays Latched Alarms instead of Current Alarms.

RX MAJOR (Menu):**Status**

SIGNAL LOCK:	{Pass/Fail} The Carrier Lock is currently or has alarmed since last clearing.
SYNTH PLL:	{Pass/Fail} The On-Board Phase-Locked Loop is currently or has alarmed since last clearing.
INPUT LEVEL:	{Pass/Fail} The Input Level is currently or has alarmed since last clearing.
CLOCK ACTIVITY:	{Pass/Fail}
CARRIER COMM:	{Pass/Fail} Communications have failed with the Internal Carrier Control Subsystem since the last clearing.
DEMOD COMM:	{Pass/Fail} Communications have failed with the Internal Demodulation Control Subsystem since last clearing.
<u>FPGA CONFIG:</u>	{Pass/Fail}
DJIT CFG:	{Pass/Fail} The DJIT FPGA is currently or has alarmed since last clearing.
TERR INTFC CFG:	{Pass/Fail} The Terrestrial Card FPGA is currently or has alarmed since last clearing.

RX MINOR (Menu):**Status**

DATA ACTIVITY:	{Pass/Fail} The Rx Data is currently or has alarmed since last clearing.
BUFF UNDERFLOW:	{Pass/Fail}

The signal buffer has completely emptied and reset, since latched alarms were last cleared. This menu is only available if the terrestrial interface is buffer capable.

BUFF NEAR EMPTY:	{Pass/Fail} The signal buffer has reached a near empty value since latched alarms were last cleared. This menu is only available if the terrestrial interface is buffer capable.
BUFF NEAR FULL:	{Pass/Fail} The signal buffer has reached a near full value since latched alarms were last cleared. This menu is only available if the terrestrial interface is buffer capable.
BUFF OVERFLOW:	{Pass/Fail} The signal buffer has completely filled and reset, since latched alarms were last cleared. This menu is only available if the terrestrial interface is buffer capable.
EXC CLOCK:	{Pass/Fail} The signal buffer external clock detection has failed since latched alarms were last cleared. This menu is only available if the terrestrial interface is buffer capable.
EXC PLL LOCK:	{Pass/Fail} The signal buffer external clock being routed to the terrestrial interface PLL lost detection since latched alarms were last cleared. This menu is only available if the terrestrial interface is buffer capable.
DEMOD LOCK:	{Pass/Fail} The Demod Lock is currently or has alarmed since last clearing.
IFEC LOCK:	{Pass/Fail} The Inner Forward Error Correction is currently or has alarmed since last clearing.
OFEC LOCK:	{Pass/Fail} The Outer Forward Error Correction is currently or has alarmed since last clearing.
FRAME SYNC:	{Pass/Fail} The DVB Frame Sync is currently or has alarmed since last clearing.
EBNO:	{Pass/Fail} The Eb/No is currently on has alarmed since last clearing.
IP DEST ADDR	{Pass/Fail}

Fail indicates the EDI has not received an ARP reply to its ARP requests and thus has not been able to resolve the destination MAC address.

ETH LINK**{Pass/Fail}**

Fail indicates that the Ethernet Data Interface has not been able to establish a valid physical connection on its Ethernet data port.

COMMON (Menu):**+5V SUPPLY:****{Pass/Fail}**

The +5 V Supply is currently or has alarmed since last clearing.

+12V SUPPLY:**{Pass/Fail}**

The +12 V Supply is currently or has alarmed since last clearing.

-12V SUPPLY:**{Pass/Fail}**

-12 V Supply is currently or has alarmed since last clearing. Only on units with a HSSI or ECL BAL/UNBAL Terrestrial Interface installed.

+24V SUPPLY:**{Pass/Fail}**

The +24 V Supply is currently or has alarmed since last clearing.

DEMOD HW FAULT:**{Pass/Fail}****CLEAR LATCHED ALARMS: {False/True}**

This screen is used to clear all latched alarms.

4.2.6 System Menu Options and Parameters

The System Screens are shown in Figure 4-10. These include:

DATE (MM/DD/YY):

Displays the current date.

TIME (HH:MM:SS):

Displays the current time.

FRONT PANEL (Menu):**BKLT LEVEL:****{HIGH, MED, LOW, OFF}**

Sets the backlight intensity level.

BKLT TIMEOUT:**{0 – 99}**

Allows the user to enter the amount of time in seconds for the backlight to dim. Enter '0' for no timeout.

KEY CLICK:**{ON, OFF}**

Allows the user to choose between silent and audible button depression.

MENU NAVIGATION:**{STANDARD, FLOATING}**

Standard: This setting has a fixed starting point for all sub-menus.

Floating: Sub-menus are floating, always returning to the last menu that was accessed.

REMOTE PORT (Menu):**ADDRESS:**

Sets the multi-drop address of the remote port.

BAUD RATE:

{150, 300, 600, 1200, 2400, 4800, 9600, 19200, 38400}

Allows user to set the remote port baud rate for Terminal and Computer Mode.

TCP/IP (Menu): (Remote Protocol Only)**BOOT MODE:****{Default, NonVol, Bootp}**

Default: If no Ethernet Interface is to be used. No IP Address or mask changes will be allowed.

NonVol: Stores and uses IP Mask and addresses as provided by the user.

Bootp: At boot time, use Bootp Protocol to get names, masks, and IP Addresses of the modem, router, and server.

BOOTp SERVER TAG:**{128 – 257, default is 206}**

Only used if Bootp is selected in Boot Mode. Should be consistent with the tag expected by the users Bootp Server.

MODEM HOST

The Host Modem for the network.

IP ADDR MASK:**{255.XXX.XXX.XXX}**

The IP Address Mask of the local network. The mask is expressed in a decimal format, and must be a valid TCP/IP Mask.

255.255.255.128

255.255.252.000

255.000.000.000

This field should be set before changes are made to the Modem or Router Address.

MODEM IP ADDR:**{XXX.XXX.XXX.XXX}**

The IP Address of the modem. This address should be consistent for the mask defined. This address is expressed in decimal format. For example:

For the decimal Modem IP Octets:

172.18.100.212

Mask: 255.255.000.000

Modem IP Address: AC.12.64.D4

Broadcast and loop back addresses will not be allowed. These are addresses with all subnet bits set to 0's or 1's.

SERVER IP ADDR:**{XXX.XXX.XXX.XXX}**

The IP Address of the Boot Server and the address of the SNMP Trap Server when SNMP is active. If a server is used and there is no local router, this address must be consistent with the modem address. If a router has been specified, the address is presumed to be reachable via the router. For example:

For the modem 172.18.100.212

No router, and server: 172.18.28.253

Mask: 255.255.000.000

Modem: 172.18.100.212

Router: 171.000.000.1

Server: 172.18.40.15

For the modem 172.18.100.212

Router on the same network: 172.18.1.5 and
server on a different network: 196.24.14.250

Mask: 255.255.000.000

Modem: 172.18.100.212

Router: 172.18.1.5

Server: 196.24.14.250

Broadcast and loop back addresses will not be allowed. These are addresses with all subnet bits set to 0's or 1's.

ROUTER IP ADDR:**{XXX.XXX.XXX.XXX}**

The IP Address of the Local Network Router. If a router is present on the local network, this address must be consistent with the IP Mask and the subnet of the modem. If no router is present, then the address should be set to a foreign address. This address is expressed in decimal format. For example:

For the modem 172.18.100.212

No router, and server: 172.18.1.5

Mask: 255.255.000.000

Modem: 172.18.100.212

Router: 172.12.1.5

For the modem 172.18.100.212

With no local router

Mask: 255.255.000.000

Modem: 172.18.100.212

Router: 160.000.000.01

Broadcast and loop back addresses will not be allowed. These are addresses with all subnet bits set to 0's or 1's.

ETHER RATE:

{10 Mbps/HD/FD}

The data rate for the local Ethernet Interface.

10 Mbps/HD/FD – for 10 Base T in either half-duplex or full duplex.

SNMP (Menu):

A description of OID organization is provided in the MIB portion of this manual

SNMP VERSION:

{V1 & V2, V3}

This selection controls the SNMP Version that will be used in messaging between the equipment and it's host.

When V1 & V2 is used, RD COMMUNITY and RDWR COMMUNITY are used to determine the authorization of an incoming message.

When V3 is used, three contexts are supported: **public**, **mib2**, and **dev**. Context, Authentication and Privacy are a portion of each SNMPV3 message.

The **public** context will only allow the user to see the sysoid of the unit. This is the most restricted access possible and only allows the unit to be identified by a host SNMP Station.

The **mib2** context allows a user with appropriate authentication to access the mib2 OIDs and the SNMP OIDs. These are of interest primarily to network operators not controlling the satellite link.

The **dev** context allows a user with appropriate authentication to access the device control portion of the MIB. These OIDs are used to control the devices satellite link and operation.

TRAP VERSION:

{V1, V2}

This controls the type of message format used when a message trap is generated by the equipment and bound for a SNMP Host. Messages will only be sent if the unit has been authorized to do so.

AUTHORIZATION:

{TRAPS OFF, TRAPS ON}

This controls the type of message format used when a message trap is generated by the equipment and bound

for a SNMP host. Messages will only be sent if the unit has been authorized to do so.

RD COMMUNITY:**{16 characters of name}**

This menu is only displayed when SNMP VERSION is set to V1 & V2.

This is the community that a host must be acting within when an OID variable is requested by a V1/V2 SNMP message.

RDWR COMMUNITY: {16 characters of name}

This menu is only displayed when SNMP VERSION is set to V1 & V2.

This is the community that a host must be acting within when an OID variable is being changed by a V1/V2 SNMP message.

USER 1-4 (Menus):**{16 characters of name}**

These menus are only displayed when SNMP VERSION is set to V3.

This device supports five users. The first user is the public user which is always available and cannot be configured. The other four users are configured via the following sub menu items.

The user entries are decorated with the current user name.

User1 reset value = Viewer-md5
 User2 reset value = Viewer-sha
 User3 reset value = Oper-md5
 User4 reset value = Oper-sha

The reset values have been selected to reflect the combinations of access groups and authentication methods being used.

The names may be changed by pressing enter and using the arrow keys to select from characters.

ACCESS GROUP:**{NO GROUP, OPER, VIEWER, DEV OPER, NET OPER, DEV VIEWER, NET VIEWER}**

User1 reset value = VIEWER
 User2 reset value = VIEWER
 User3 reset value = OPER
 User4 reset value = OPER

Each access group requires a context, authentication and privacy level. If a device operation group is selected and the authentication or privacy level requirement is not met, any SNMP messages received will be rejected.

AUTH PASSWORD: {16 characters}

User1 reset value = Viewer
User2 reset value = Viewer
User3 reset value = Oper
User4 reset value = Oper

This is a case sensitive entry which is used to authenticate the user. The password is encrypted using the authentication method selected in the sibling menu. If a message arrives and the authentication does not match the authentication key the SNMP messages will be rejected.

The password may be changed by pressing enter and using the arrow keys to select from characters.

PRIV PASSWORD: {16 characters}

User1 reset value = Viewer
User2 reset value = Viewer
User3 reset value = Oper
User4 reset value = Oper

This is a case sensitive entry which is used to provide privacy for the SNMP message. The password is encrypted using the privacy method selected in the sibling menu. If a message arrives and the authentication matches but privacy type does not match the SNMP messages will be rejected.

The password may be changed by pressing enter and using the arrow keys to select from characters.

AUTHENTICATION: { NONE, MD5, SHA }

User1 reset value = MD5
User2 reset value = SHA
User3 reset value = MD5
User4 reset value = SHA

This is the encryption method used to provide a key for the authentication password. MD5 is generally considered faster, and SHA is slightly quicker. The host station and the equipment must both use the same method.

PRIVACY: { NONE, DES }

User1 reset value = DES
User2 reset value = DES
User3 reset value = DES

User4 reset value = DES

This is the encryption method used to provide a key for the message privacy. If a group access requires privacy DES must be selected. The host station and the equipment must both use the same method.

USER RESET:

Pressing enter will reset the ACCESS GROUP, AUTH PASSWORD, PRIV PASSWORD, AUTHENTICATION, and PRIVACY for the current user submenu.

HW/FW CONFIG (Menu):

Allows the user to view and edit the hardware and firmware configurations.

DD240:

{EVALUATION, SERIES 100, SERIES 200, SERIES 300, SERIES 350}

This screen displays the feature set enabled in the software.

FIRMWARE REV:

{F04677.Y.MMDDYY}

Displays the main board assembly number where 4677.XX.XX.XX = the firmware set release number.

M&C REV:

{X.XX}

This screen is used to display the M&C Revision.

MAIN BOARD:

SERIAL NUMBER#:

Displays the main board serial number.

PC NUMBER:

{PC/XXXXNN}

Displays the main board printed circuit card number where XXXX = the card number, and NN = the revision number.

ASSEMBLY NUMBER#:

{AS/XXXXNN}

Displays the main board assembly number where XXXX = the assembly number, and NN = the revision number.

DEMOD BOARD:

FIRMWARE REV:

{XXXXXXXXX}

Displays the Demod Board Firmware Revision Number.

TYPE:

These 16 alphanumeric characters display the Hardware Daughter Card Identifier.

BOARD ID:

{0 - 7}

Displays the Communication ID for Internal Demod Daughter Card.

TERR INTFC BRD:

FIRMWARE REV:

Displays firmware revision of terrestrial interface board.

TYPE:	Terrestrial interface board type.
BOARD ID:	Displays hardware revision of terrestrial interface board.

4.2.7 Test Menu Options and Parameters

TEST (Menu):

TEST PATTERN:	{NONE, 2¹⁵-1, 2²³-1} This is used to select the test pattern being received. To start a test the 2 ¹⁵ -1 or the 2 ²³ -1 values should be selected. The test values may be frozen and recorded by setting TEST PATTERN to NONE, the value will not be cleared unless TEST PATTERN is changed again, TEST RESET is used, synchronization is lost, or the unit's power is cycled.
PATTERN SYNC:	{TRUE, FALSE} This is a read only status value. The value indicates whether the test pattern is being successfully detected. The runtime, bit count, and bit error count will not start until synchronization has been achieved.
EARLY SYNC LOSS:	{TRUE, FALSE} This is a read only status value. The value indicates whether the test pattern was successfully detected and then lost since the test pattern was selected. Note: Once a pattern synchronization loss occurs BIT ERRORS, TOTAL BIT COUNT, BIT ERROR RATE and RUN TIME will be reset to zero. Once pattern synchronization re-occurs BIT ERRORS, TOTAL BIT COUNT, BIT ERROR RATE and RUN TIME will start counting from zero.
PATTERN SENSE:	{NORMAL, INVERTED} This is a read only status value. The value indicates whether the test pattern is detected as an inverted or non-inverted. This value should correspond to the pattern sense used by the transmitting equipment.
BIT ERRORS:	{64 BIT VALUE, >=0} This is a read only status value. The value indicates absolute count of bit errors detected since synchronization.
TOTAL BIT COUNT:	{M.ppppppE+ee} This is a read only status value. This is a scientific notation value where the mantissa is given with six-point precision and the exponent may be as large as +32.

The value indicates absolute count of data bits received since synchronization.

BIT ERROR RATE:	{M.ppE+ee} This is a read only status value. This is a scientific notation value where the mantissa is given with two-point precision and the exponent may be as large as +32. The value indicates absolute count of bit errors divided by the absolute count of data bits received since synchronization.
RUN TIME:	{DD:HH:MM:SS} This is a read only status value. This displays the Days:Hours:Minutes:Seconds that the test has been running without an interruption in synchronization.
TEST RESET:	{} Pressing the enter button on the front panel will reset test measurements but not the test pattern. The test values are updated as soon as synchronization is achieved.
OUTER FEC:	{NORMAL, BYPASS} Test mode to allow bypassing the LDPC decoder. Available when DVBS2 is selected.
INNER FEC:	{NORMAL, BYPASS} Test mode to allow bypassing the BCH decoder. Available when DVBS2 is selected.
INTERLEAVER:	{NORMAL, BYPASS} .
BB SCRAMBLER:	{NORMAL, BYPASS} Test mode to allow bypassing the base band scrambler. Available when DVBS2 is selected.
PL SCRAMBLER:	{NORMAL, BYPASS} .
ETH DEST MAC	{XXXXXXXXXXXX} This field allows the operator to enter a Destination MAC address to be used by the Ethernet Data Interface. When this field is non-zero, the Ethernet Data Interface will use this value for the Destination MAC address instead of trying to resolve the Destination MAC address in the normal manner. When this field is zero, the

Ethernet Data Interface will resolve the Destination MAC using ARP for Unicast IP Addresses and automatic construction for Multicast IP Addresses.

ETH TEST DATA

{ENABLED / DISABLED}

This field allows the operator to test LAN connectivity and routing without requiring an input IF signal for the DD240 to demodulate. When enabled, the Ethernet Data Interface will generate a test MPEG stream at the programmed data rate. This test stream consists of MPEG packets with the following contents:

- Sync byte (0x47)
- Second byte that increments once per MPEG packet
- 186 data bytes that are a running counter that increments each byte across all MPEG packets

The Ethernet Data Interface will lock to this stream as though it were actual demodulated data and generate the appropriate UDP, RTP, and FEC packets depending up the operational mode.

4.3 Host Computer Remote Communications

Control and status messages are conveyed between the DD240 and the subsidiary modems and the host computer using packetized message blocks in accordance with a proprietary communications specification. This communication is handled by the Radyne Link Level Protocol (RLLP), which serves as a protocol 'wrapper' for the RM&C data.

Complete information on monitor and control software is contained in the following sections.

4.3.1 Protocol Structure

The Communications Specification (COMMSPEC) defines the interaction of computer resident Monitor and Control software used in satellite earth station equipment such as modems, redundancy switches, multiplexers, and other ancillary support gear. Communication is bi-directional, and is normally established on one or more full-duplex 9600-baud multi-drop control buses that conform to EIA Standard RS-485.

Each piece of earth station equipment on a control bus has a unique physical address, which is assigned during station setup/configuration or prior to shipment. Valid decimal addresses on one control bus range from 032 through 255 for a total of up to 224 devices per bus. Address 255 of each control bus is usually reserved for the M&C computer.

4.3.2 Protocol Wrapper

The Radyne COMMSPEC is byte-oriented, with the Least Significant Bit (LSB) issued first. Each data byte is conveyed as mark/space information with one marks comprising the stop data. When the last byte of data is transmitted, a hold comprises one steady mark (the last stop bit). To begin or resume data transfer, a space (00h) substitutes this mark. This handling scheme is controlled by the hardware and is transparent to the user. A pictorial representation of the data and its surrounding overhead may be shown as follows:

ST	B ₀	B ₁	B ₂	B ₃	B ₄	B ₅	B ₆	B ₇	S1	ST, etc.
----	----------------	----------------	----------------	----------------	----------------	----------------	----------------	----------------	----	-------------

The stop bit S1 is a mark. Data flow remains in a hold mode until the start bit ST is replaced by a space. The start bit (ST) is not part of the actual data (B₀ - B₇).

The above byte-oriented protocol is standard for UART based serial communication ports such as Workstation or Personal Computer (PC) COM ports. COM ports should be configured for 8 data bits, no parity, and one stop bit. For example, for 9600-baud operation, COM ports should be configured as:

9600, 8, N, 1

The COMMSPEC developed for use with the Radyne Link Level Protocol (RLLP) organizes the actual monitor and control data within a shell, or "protocol wrapper", which surrounds the data. The format and structure of the COMMSPEC message exchanges are described herein. Decimal numbers have no suffix; hexadecimal numbers end with a lower case h suffix and binary values have a lower case b suffix. Thus, 22 = 16h = 000010110b. The principal elements of a data frame, in order of occurrence, are summarized as follows:

<SYN> - the message format header character, or ASCII sync character, that defines the beginning of a message. The <SYN> character value is always 16h.

<BYTE COUNT> - the Byte Count is the number of bytes in the <DATA> field, ranging from 0 through 509. This field is 2 bytes long for the DD240 protocol.

<SOURCE ID> - the Source Identifier defines the multi-drop address origin. Note that all nodes on a given control bus have a unique address that must be defined.

<DESTINATION ID> - The Destination Identifier serves as a pointer to the multi-drop destination device that indicates where the message is to be sent.

<FRAME SEQUENCE NUMBER> - The FSN is a tag with a value from 0 through 255 that is sent with each message. It assures sequential information framing and correct equipment acknowledgment and data transfers.

<OPCODE> - The Operation Code field contains a number that identifies the message type associated with the data that follows it. Equipment under MCS control recognizes this field firmware identification and subsequently steers the DATA accordingly to perform a specific function or series of functions. Acknowledgment and error codes are returned in this field. This field is 2 Bytes for the DD240 protocol.

<...DATA...> - The Data field contains the binary, bi-directional data bytes associated with the <OPCODE>. The number of data bytes in this field is indicated by the <BYTE COUNT> value.

<CHECKSUM> - The checksum is the module 256 sum of all preceding message bytes, excluding the <SYN> character. The checksum determines the presence or absence of errors within the message. In a message block with the following parameters, the checksum is computed as shown below in Table 4-1.

BYTE FIELD	DATA CONTENT	RUNNING CHECKSUM
<BYTE COUNT> (Byte 1)	00h = 00000000b	00000000b
<BYTE COUNT> (Byte 2)	02h = 00000010b	00000010b
<SOURCEID>	F0h = 11110000b	11110010b

<DESTINATION ID>	2Ah = 00101010b	00011100b
<FSN>	09h = 00001001b	00100101b
<OPCODE> (Byte 1)	00h = 00000000b	00100101b
<OPCODE> (Byte 2)	03h = 00000011b	00101000b
<DATA> (Byte 1)	DFh = 11011111b	00000111b
<DATA> (Byte 2)	FEh = 11111110b	00000101b

Thus, the checksum is 00000101b; which is 05h or 5 decimal. Alternative methods of calculating the checksum for the same message frame are:

$$00h + 02h + F0h + 2Ah + 09h + 00h + 03h + DFh + FEh = 305h.$$

Since the only concern is the modulo 256 (modulo 100h) equivalent (values that can be represented by a single 8-bit byte), the checksum is 05h.

For a decimal checksum calculation, the equivalent values for each information field are:

$$0 + 2 + 240 + 42 + 9 + 0 + 3 + 223 + 254 = 773;$$

$$773/256 = 3 \text{ with a remainder of } 5. \text{ This remainder is the checksum for the frame.}$$

$$5 \text{ (decimal)} = 05h = 0101b = \text{<CHECKSUM>}$$

4.3.3 Frame Description and Bus Handshaking

In a Monitor and Control environment, every message frame on a control bus port executes as a packet in a loop beginning with a wait-for-SYN-character mode. The remaining message format header information is then loaded, either by the M&C computer or by a subordinate piece of equipment requesting access to the bus. Data is processed in accordance with the OPCODE, and the checksum for the frame is calculated. If the anticipated checksum does not match then a checksum error response is returned to the message frame originator. The entire message frame is discarded and the wait-for-SYN mode goes back into effect. If the OPCODE resides within a command message, it defines the class of action that denotes an instruction that is specific to the device type, and is a prefix to the DATA field if data is required. If the OPCODE resides within a query message packet, then it defines the query code, and can serve as a prefix to query code DATA.

The Frame Sequence Number (FSN) is included in every message packet, and increments sequentially. When the M & C computer or bus-linked equipment initiates a message, it assigns the FSN as a tag for error control and handshaking. A different FSN is produced for each new message from the FSN originator to a specific device on the control bus. If a command packet is sent and not received at its intended destination, then an appropriate response message is not received by the packet originator. The original command packet is then re-transmitted with the same FSN. If the repeated message is received correctly at this point, it is considered a new message and is executed and acknowledged as such.

If the command packet is received at its intended destination but the response message (acknowledgment) is lost, then the message originator (usually the M&C computer) re-transmits the original command packet with the same FSN. The destination device detects the same FSN and recognizes that the message is a duplicate, so the associated commands within the packet are not executed a second time. However, the response packet is again sent back to the source as an acknowledgment in order to preclude undesired multiple executions of the same command.

To reiterate, valid equipment responses to a message require the FSN tag in the command packet. This serves as part of the handshake/acknowledge routine. If a valid response message is absent, then the command is re-transmitted with the same FSN. For a repeat of the same command involving iterative processes (such as increasing or decreasing transmit power level), the FSN is incremented after each message packet. When the FSN value reaches 255, it overflows and begins again at zero. The FSN tag is a powerful tool that assures sequential information framing, and is especially useful where commands require more than one message packet.

The full handshake/acknowledgment involves a reversal of source and destination ID codes in the next message frame, followed by a response code in the <OPCODE> field of the message packet from the equipment under control.

If a command packet is sent and not received at its intended destination, a timeout condition can occur because a response message is not received by the packet originator. On receiving devices slaved to an M & C computer, the timeout delay parameters may be programmed into the equipment in accordance with site requirements by Radyne Corporation prior to shipment, or altered by qualified personnel. The FSN handshake routines must account for timeout delays and be able to introduce them as well.

4.3.4 Global Response Operational Codes

In acknowledgment packets the operational code, <OPCODE>, field of the message packet is set to 0 by the receiving devices when the message intended for the device is evaluated as valid. The device that receives the valid message then exchanges the <SOURCE ID> with the <DESTINATION ID>, sets the <OPCODE> to zero in order to indicate that a good message was received, and returns the packet to the originator. This "GOOD MESSAGE" Opcode is one of three global responses.

If a bad parameter or inconsistent value is sent in an RLLP Message, the reply packet will have an operational code value of 00FFh and the unit will log an event. The operator should inspect the event log to determine the reason for a message failure.

RESPONSE OPCODE DESCRIPTION	OPCODE
Good Message	000d = 0000h
Bad Parameter	255d = 00FFh
Bad Opcode	254d = 00FEh

4.3.5 Collision Avoidance

When properly implemented, the physical and logical devices and ID addressing scheme of the COMMSPEC normally precludes message packet contention on the control bus. The importance of designating unique IDs for each device during station configuration cannot be overemphasized. One pitfall, which is often overlooked, concerns multi-drop override IDs. All too often, multiple devices of the same type are assigned in a direct-linked ("single-thread") configuration accessible to the M&C computer directly. For example, if two DD240 Demodulators with different addresses (DESTINATION IDs) are linked to the same control bus at the same hierarchical level, both will attempt to respond to the M&C computer when the computer generates a multi-drop override ID of 23. If their actual setup parameters, status, or internal timing differs, they will both attempt to

respond to the override simultaneously with different information, or asynchronously in their respective message packets and response packets, causing a collision on the serial control bus.

To preclude control bus data contention, different IDs must always be assigned to the equipment. If two or more devices are configured for direct-linked operation, then the M&C computer and all other devices configured in the same manner must be programmed to inhibit broadcast of the corresponding multi-drop override ID.

The multi-drop override ID is always accepted by devices of the same type on a common control bus, independent of the actual DESTINATION ID. These Override IDs with the exception of "BROADCAST" are responded to by all directly linked devices of the same type causing contention on the bus. The "BROADCAST" ID, on the other hand, is accepted by all equipment but none of them returns a response packet to the remote M&C.

The following multi-drop override IDs are device-type specific, with the exception of "BROADCAST". These are summarized below with ID values expressed in decimal notation:

Note that multi-drop override ID 01 can be used interchangeably to broadcast a message to a DMD-3000/4000 modem, a DMD-4500/5000, a DMD15 modem, or a DVB3030. Radyne Corporation recommends that the multi-drop override IDs be issued only during system configuration as a bus test tool by experienced programmers, and that they not be included in run-time software. It is also advantageous to consider the use of multiple bus systems where warranted by a moderate to large equipment complement.

Therefore, if a DMD15 Modulator is queried for its equipment type identifier, it will return a "20" and DMD15 Demodulator will return a "21". A DMD15 Modem will also return a "22". A DVB3030 Video Modulator will return a "23."

4.3.6 Software Compatibility

The COMMSPEC, operating in conjunction within the RLLP shell, provides for full forward and backward software compatibility independent of the software version in use. New features are appended to the end of the DATA field without OPCODE changes. Older software simply discards the data as extraneous information without functional impairment for backward compatibility.

If new device-resident or M&C software receives a message related to an old software version, new information and processes are not damaged or affected by the omission of data.

The implementation of forward and backward software compatibility often, but not always, requires the addition of new Opcodes. Each new function requires a new Opcode assignment if forward and backward compatibility cannot be attained by other means.

Directly-Addressed Equipment	Multi-Drop Override ID
Broadcast (all directly-linked devices)	00
DMD-3000/4000, 4500 or 5000 Mod Section, DMD15	01
DMD-3000/4000, 4500 or 5000 Demod Section, DMD15	02
RCU-340 1:1 Switch	03
RCS-780 1:N Switch	04
RMUX-340 Cross-Connect Multiplexer	05

CDS-780 Clock Distribution System	06
SOM-340 Second Order Multiplexer	07
DMD-4500/5000 Modulator Section	08
DMD-4500/5000 Demodulator Section	09
RCU-5000 M:N Switch	10
DMD15 Modulator	20
DMD15 Demodulator	21
DMD15 Modem	22
DVB3030 Video Modulator, DD240	23
Reserved for future equipment types	24-31

When Radyne Corporation equipment is queried for information (Query Mod, Query Demod, etc.) it responds by sending back two blocks of data; a non-volatile section (parameters that can be modified by the user) and a volatile section (status information). It also returns a count value that indicates how large the non-volatile section is. This count is used by M&C developers to index into the start of the volatile section.

When new features are added to Radyne Corporation equipment, the control parameters are appended to the end of the non-volatile section, and status of the features, if any, are added at the end of the volatile section. If a remote M&C queries two pieces of Radyne Corporation equipment with different revision software, they may respond with two different sized packets. The remote M&C MUST make use of the non-volatile count value to index to the start of the volatile section. If the remote M&C is not aware of the newly added features to the Radyne Corporation product, it should disregard the parameters at the end of the non-volatile section and index to the start of the volatile section.

If packets are handled in this fashion, there will also be backward-compatibility between Radyne Corporation equipment and M&C systems. Remote M&C systems need not be modified every time a feature is added unless the user needs access to that feature.

4.3.7 RLLP Summary

The RLLP is a simple send-and-wait protocol that automatically re-transmits a packet when an error is detected, or when an acknowledgment (response) packet is absent.

During transmission, the protocol wrapper surrounds the actual data to form information packets. Each transmitted packet is subject to 'time out' and 'frame sequence' control parameters, after which the packet sender waits for the receiver to convey its response. Once a receiver verifies that a packet sent to it is in the correct sequence relative to the previously received packet, it computes a local checksum on all information within the packet excluding the <SYN> character and the <CHECKSUM> fields. If this checksum matches the packet <CHECKSUM>, the receiver processes the packet and responds to the packet sender with a valid response (acknowledgment) packet. If the checksum values do not match, the receiver replies with a negative acknowledgment (NAK) in its response frame.

The response packet is therefore either an acknowledgment that the message was received correctly, or some form of a packetized NAK frame. If the sender receives a valid acknowledgment (response) packet from the receiver, the <FSN> increments and the next packet is transmitted as required by the sender. However, if a NAK response packet is returned the sender re-transmits the original information packet with the same embedded <FSN>.

If an acknowledgment (response) packet or a NAK packet is lost, corrupted, or not issued due to an error and is thereby not returned to the sender, the sender re-transmits the original information packet; but with the same <FSN>. When the intended receiver detects a duplicate packet, the packet is acknowledged with a response packet and internally discarded to preclude undesired repetitive executions. If the M&C computer sends a command packet and the corresponding response packet is lost due to a system or internal error, the computer times out and re-transmits the same command packet with the same <FSN> to the same receiver and waits once again for an acknowledgment or a NAK packet.

To reiterate, the format of the message block is shown in Table 4-4, Link Level Protocol Message Block.

Table 4-4. Link Level Protocol Message Block							
SYNC	COUNT	SRC ADDR	DEST ADDR	FSN	OP CODE	DATA BYTES	CHECKSUM

4.3.8 Remote Port Packet Structure

The RLLP Remote Port Packet structure is as follows:

<SYNC>:	Message format header character that defines the beginning of a message. The <SYNC> character value is always 0x16. (1 byte).
<BYTE COUNT>:	Number of bytes in the <DATA> field. (2 bytes).
<SOURCE ID>:	Identifies the address of the equipment from where the message originated. (1 byte).
<DEST. ID>:	Identifies the address of the equipment where the message is to be sent. (1 byte).
<FSN>:	Frame sequence number ensures correct packet acknowledgment and data transfers. (1 byte).
<OPCODE>:	This field identifies the message type associated with the information data. The equipment processes the data according to the value in this field. Return error codes and acknowledgment are also included in this field. (2 bytes).
<...DATA...>:	Information data. The number of data bytes in this field is indicated by the <BYTE COUNT> value.
<CHECKSUM>:	The modulo 256 sum of all preceding message bytes excluding the <SYNC> character. (1 byte).

4.3.9 DD240XR Opcode Command Set

The data rate and symbol rate values must be range checked when altering: Data Rate, Symbol Rate, Inner FEC, Modulation Type, or Framing. Use the following formulas for range checking:

$$\text{Max Symbol Rate} \geq \text{Symbol Rate} = (\text{Data Rate} * \text{Overhead}) / (\text{Code Rate} * \text{Modulation})$$

$$\text{Max Data Rate} \geq \text{Data Rate} = (\text{Symbol Rate} * \text{Code Rate} * \text{Modulation}) / \text{Overhead}$$

Overhead	204/188 when framing is set to 188 bytes. 204/204 when framing is set to 204 bytes. 204/187 when framing is set to none.
----------	--

Modulation	16QAM = 4 8PSK = 3 QPSK = 2
------------	-----------------------------------

Code Rate	1/2, 2/3, 5/6, 3/4, 7/8, 8/9
-----------	------------------------------

Also, if an interface is being used which does not have buffering capability the buffer size may only be set to 0 milliseconds.

Other restrictions, rules or formatting are described in the front panel or SNMP MIB portions of the equipment manual.

The DD240 Opcode Command Set is listed below.

4.3.9.1 Demodulator Command Set

Queries	Opcode
Query Configuration and Status	2401h
Query Status	240Ch
Query Latched Alarms	2406h
Query Current Alarms	2409h
Query Time	240Eh
Query Date	240Fh
Query Test Status	2440h
Query Terrestrial Gig Ethernet Configuration	2550h
Query Terrestrial Gig Ethernet Status	2551h

Commands	Opcode
Set configuration	2A00h
Set frequency	2A01h
Set data rate	2A02h
Set acquisition range	2A04h
Set demodulation	2A07h
Set inner FEC rate	2A08h
Set network specification	2A0Bh
Set spectral inversion	2A0Fh
Set buffer size	2A10h
Set Rx clock source	2A11h
Set Rx Clock Polarity	2A12h
Set satellite framing	2A13h
Set PRBS test pattern	2A17h
Set terrestrial interface type	2A1Fh
Center buffer	2A20h
Set data polarity	2A21h
Set terrestrial framing	2A40h
Set Nyquist roll off	2A41h
Set symbol rate	2A43h
Set terrestrial streaming	2A44h
Clear events	2A45h
Reset test	2A46h
Clear latched alarms	2C03h

Set time	2C04h
Set date	2C05h
Set Terrestrial Gig Ethernet Configuration	2B50h
Clear Terrestrial Gig Ethernet	2B51h

4.3.10 Detailed Command Descriptions

Opcode: <2401h> Query Configuration and Status

Response		
<1>	Number of configuration bytes	Number of Configuration Bytes
Configuration Bytes		
<1>	Network Specification	0 = DVB, 1=DVB-S2, 2=DTV-AMC
<4>	Carrier Frequency	in 1 Hz steps, If range = 50 MHz to 180 MHz, L-Band Range = 950 MHz to 2150 MHz
<1>	Demodulation	0 = QPSK, 2 = 8PSK, 3 = 16QAM, 4 = 16APSK
<1>	Inner FEC Rate	1 = 1/2 Rate, 2 = 2/3 Rate, 3 = 3/4 Rate, 4 = 5/6 Rate, 5 = 7/8 Rate, 8 = 8/9 Rate, 9 = 9/10 Rate, 10 = 10/11 Rate, 11 = 11/12 Rate, 12 = 3/5 Rate, 13 = 4/5 Rate, 14 = 6/7 Rate, 15 = Reserved, 16 = Reserved, 17 = Reserved
<4>	Data Rate	in 1 bps steps
<4>	Symbol Rate	symbols per second
<1>	Spectral Inversion	0 = Inverted, 1 = Normal
<1>	Nyquist roll off	0 = 0.35, 20 = 0.20, 25 = 0.25
<1>	Last rate control	0 = Symbol Rate, 1 = Data Rate, 2 = Auto
<4>	Acquisition Range	in 1 Hz steps, Max 7.5 MHz, Min: Symbol Rate/10 and when demodulation is 8PSK Min: Symbol Rate/20
<1>	LNB DC Power	0 = disable, 1 = enable
<1>	Interface	0 = RS422 Serial, 2 = ASI, 3 = AASI, 4=G703E3 UNBAL, 5=G703T3 UNBAL, 6=G703STS1 UNBAL, 7= HSSI, 8 = DVB Parallel, 9 = M2P Parallel, 10 = ECL BAL/UNBAL, 11 = GIGE
<1>	Terrestrial Framing	0 = 188 byte, 1 = 204 byte, 2 = no framing
<1>	Data Polarity	0 = normal, 1 = inverted

<1>	Rx Clock Source	3 = RXSAT, 4 = EXC direct, 5 = EXC Referenced PLL
<1>	Rx Clock Polarity	0 = normal, 1 = inverted
<1>	Buffer Size	in 1 msec steps, Range = 0 msec to 64 msec
<4>	Exc Clock Frequency	1000000 1544000 2000000 2048000 5000000 6312000 8448000 10000000
<1>	Test Pattern	0 = none, 1 = $(2^{15} - 1)$, 23 = $(2^{23} - 1)$
<2>	Eb/No Alarm Limit	With implied decimal point. 1030 = 10.30 dB. Range 100 to 1500, 1.00 to 15.00 dB
<1>	Major Alarms Mask 1	Bit 0 = loss of signal lock Bit 1 = loss of synthesizer PLL lock Bit 2 = input level alarm Bit 3 = reserved for POST alarm Bit 4 = FPGA configuration alarm Bit 5 = reserved for deframer FIFO fault Bit 6 = reserved for deframer PLL lock fault Bit 7 = carrier subsystem comm fault 0 = Mask, 1 = Allow
<1>	Major Alarms Mask 2	Bit 0 = demod subsystem comm fault Bit 1 = loss of clock activity Bit 2-7 = reserved 0 = Mask, 1 = Allow
<1>	Minor Alarms Mask 1	Bit 0 = reserved for loss of buffer clock Bit 1 = loss of Rx data activity Bit 2 = loss of demodulation lock Bit 3 = loss of inner FEC lock Bit 4 = loss of outer FEC lock Bit 5 = loss of dvb frame lock Bit 6 = Eb/No alarm Bit 7 = reserved 0 = Mask, 1 = Allow
<1>	Minor Alarms Mask 2	Bit 0 = terrestrial buffer underflow Bit 1 = terrestrial buffer overflow Bit 2 = terrestrial buffer near empty Bit 3 = terrestrial buffer near full Bit 4 = exc clock activity Bit 5 = loss of exc pll lock Bit 6 = Ethernet Dest ID Bit 7 = Ethernet Link Status 0 = Mask, 1 = Allow
<1>	Common Faults Mask	Bit 0 = -12 V alarm Bit 1 = +12 V alarm Bit 2 = +5 V alarm Bit 3 = +24 V alarm Bit 4 = reserved for temperature alarm

		Bit 5 = LNB DC Supply Bit 6 = Demod HW Fault Bit 7 = reserved 0 = Mask, 1 = Allow
<1>	Pilot Symbols	0 = Off, 1 = On
<4>	PL Header Scrambles Seg. Index	Binary Value
<4>	Gold Code Seg. Index	Binary Value
<1>	Satellite Framing	0 = NORMAL FECFRAMES, 1 = SHORT FECFRAMES
Status Bytes		
<1>	Last Rate Control Status	0 = symbol rate, 1 = data rate
<1>	Major Alarms 1	Bit 0 = loss of signal lock Bit 1 = loss of synthesizer PLL lock Bit 2 = input level alarm Bit 3 = reserved for POST alarm Bit 4 = FPGA configuration alarm Bit 5 = reserved for deframer FIFO fault Bit 6 = reserved for deframer PLL lock fault Bit 7 = carrier subsystem comm fault 0 = no alarm, 1 = alarm
<1>	Major Alarms 2	Bit 0 = demod subsystem comm Fault Bit 1 = loss of clock activity Bit 2-7 = reserved 0 = no alarm, 1 = alarm
<1>	Minor Alarms 1	Bit 0 = reserved for loss of buffer clock Bit 1 = loss of Rx data activity Bit 2 = loss of demodulation lock Bit 3 = loss of inner FEC lock Bit 4 = loss of outer FEC lock Bit 5 = loss of dvb frame lock Bit 6 = Eb/No alarm Bit 7 = reserved 0 = no alarm, 1 = alarm
<1>	Minor Alarms 2	Bit 0 = terrestrial buffer underflow Bit 1 = terrestrial buffer overflow Bit 2 = terrestrial buffer near empty Bit 3 = terrestrial buffer near full Bit 4 = exc clock activity Bit 5 = loss of exc pll lock Bit 6 = Ethernet Dest ID Bit 7 = Ethernet Link 0 = no alarm, 1 = alarm
<1>	Common Faults	Bit 0 = -12 V alarm

		<p>Bit 1 = +12 V alarm Bit 2 = +5 V alarm Bit 3 = +24 V alarm Bit 4 = reserved for temperature alarm Bit 5 = LNB DC Supply Bit 6 = Demod HW Fault Bit 7 = reserved 0 = no alarm, 1 = alarm</p>
<1>	Latched Major Alarms 1	<p>Bit 0 = loss of signal lock Bit 1 = loss of synthesizer PLL lock Bit 2 = input level alarm Bit 3 = reserved for POST alarm Bit 4 = FPGA Configuration alarm Bit 5 = reserved for deframer FIFO fault Bit 6 = reserved for deframer PLL lock fault Bit 7 = carrier subsystem comm fault 0 = no alarm, 1 = alarm</p>
<1>	Latched Major Alarms 2	<p>Bit 0 = demod subsystem comm fault Bit 1 = loss of clock activity Bit 2-7 = reserved 0 = no alarm, 1 = alarm</p>
<1>	Latched Minor Alarms 1	<p>Bit 0 = reserved for loss of buffer clock Bit 1 = loss of Rx data activity Bit 2 = loss of demodulation lock Bit 3 = loss of inner FEC lock Bit 4 = loss of outer FEC lock Bit 5 = loss of dvb frame lock Bit 6 = Eb/No alarm Bit 7 = reserved 0 = no alarm, 1 = alarm</p>
<1>	Latched Minor Alarms 2	<p>Bit 0 = terrestrial buffer underflow Bit 1 = terrestrial buffer overflow Bit 2 = terrestrial buffer near empty Bit 3 = terrestrial buffer near full Bit 4 = exc clock activity Bit 5 = loss of exc pll lock Bit 6 = Ethernet Dest ID Bit 7 = Ethernet Link Status 0 = no alarm, 1 = alarm</p>
<1>	Latched Common Faults	<p>Bit 0 = -12 V alarm Bit 1 = +12 V alarm Bit 2 = +5 V alarm Bit 3 = +24 V alarm Bit 4 = reserved for temperature alarm Bit 5 = LNB DC supply Bit 6 = Demod HW Fault Bit 7 = reserved 0 = no alarm, 1 = alarm</p>
<1>	+5 Voltage	with implied decimal point. 49 = +4.9V
<1>	+12 Voltage	with implied decimal point. 118 = +11.8V

<1>	-12 Voltage	with implied decimal point and minus sign. 118 = -11.8V
<1> <2>	+24 Voltage Input Level	with implied decimal point. 245 = 24.5V in 1 dBm steps Two's Complement, Implied Decimal Point
<4>	Frequency Offset	Hz, Two's Complement
<4>	Symbol Rate Offset	Hz Two's Complement
<2>	Estimated Eb/No	dB, implied decimal point (i.e. 1030 = 10.30 dB)
<2>	Estimated BER Mantissa	with implied decimal point 493 = 4.93
<2>	Estimated BER Exponent	exponent, -6 = 10^{-6} Two's Complement
<2>	Test Pattern BER Mantissa	with implied decimal point 493 = 4.93
<2>	Test Pattern BER Exponent	exponent, -6 = 10^{-6} Two's Complement
<8>	Test Pattern Error Count	bits
<4>	Test Run Time	seconds
<1>	BER Status	Bit 0 = BER after outer FEC status (1 = valid) Bit 1 = test Pattern BER status (1 = valid)
<1>	Buffer Fill Level	percent (0 - 100)
<1>	Eb/No Validity	Bits 0 - 1: 00b = invalid, 01b = valid, 10b = Eb/No is less than indicated value, 11b = Eb/No is greater than indicated value.
<1>	Terrestrial Streaming	0 = burst packets, 1=continuous bytes
<1>	Test Early Sync Loss	0 = false, 1=true
<1>	Test Pattern Sense	0= normal, 1= inverted

Opcode: <240Ch> Query Status

Response	
	Same as <i>Status Bytes</i> from Opcode: <2401h> Query Configuration and Status

Opcode: <2406h> Query Latched alarms and

Opcode: <2409h> Query Current Alarms

Response		
<1>	Major Alarms 1	Bit 0 = loss of signal lock Bit 1 = loss of synthesizer PLL lock Bit 2 = input level alarm Bit 3 = reserved for POST alarm Bit 4 = FPGA Configuration alarm Bit 5 = reserved for deframer FIFO fault Bit 6 = reserved for deframer PLL lock fault Bit 7 = carrier subsystem comm fault 0 = no alarm, 1 = alarm
<1>	Major Alarms 2	Bit 0 = demod subsystem comm Fault Bit 1 = loss of clock activity Bit 2-7 = reserved 0 = no alarm, 1 = alarm
<1>	Minor Alarms 1	Bit 0 = reserved for loss of buffer clock Bit 1 = loss of Rx data activity Bit 2 = loss of demodulation lock Bit 3 = loss of inner FEC lock Bit 4 = loss of outer FEC lock Bit 5 = loss of dvb frame lock Bit 6 = Eb/No alarm Bit 7 = reserved 0 = no alarm, 1 = alarm
<1>	Minor Alarms 2	Bit 0 = terrestrial buffer underflow Bit 1 = terrestrial buffer overflow Bit 2 = terrestrial buffer near empty Bit 3 = terrestrial buffer near full Bit 4 = exc clock activity Bit 5 = loss of exc pll lock Bit 6 = Ethernet Dest ID Bit 7 = Ethernet Link Status 0 = no alarm, 1 = alarm
<1>	Common Faults	Bit 0 = -12 V alarm Bit 1 = +12 V alarm Bit 2 = +5 V alarm Bit 3 = +24 V alarm Bit 4 = reserved for temperature alarm Bit 5 = LNB DC Supply Bit 6 = Demod HW Fault Bit 7 = reserved 0 = no alarm, 1 = alarm

Opcode: <240Eh> Query Time

Response		
<1>	Hour	0 – 23
<1>	Minute	0 – 59
<1>	Second	0 – 59

Opcode: <240Fh> Query Date

Response		
<1>	Year	0 – 99
<1>	Month	0 – 11
<1>	Day	0 – 30

Opcode: <2550> Query Terrestrial Gig Ethernet Configuration

Response		
<8>	Mac Address	Binary Value
<4>	IP Address	Binary Address
<2>	UDP Port	0-32767
<8>	Destination Mac Address	Binary Value
<4>	Destination IP Address	Binary Value
<2>	Destination UDP Port	Binary Value
<1>	Ethernet Mode	0 = UDP 1 = COP3 2 = COP3 FEC
<1>	Block Aligned	0 = Aligned 1 = Not Aligned
<1>	FEC Column L	Binary Value
<1>	FEC Column D	Binary Value

Opcode: <2551> Query Terrestrial Gig Ethernet Status

Response		
<1>	Ethernet Port Status	0 = Down 1 = Unresolved 2 = 10 M Half 3 = 100 M Half 4 = 10 M Full 5 = 100 M Full

		6 = 1000 M Half 7 = 1000 M Full
<4>	Total Packets	Binary Value
<4>	FEC Column Packets	Binary Value
<16>	Revision	

Opcode: <2B50> Set Terrestrial Gig Ethernet Configuration

Response		
<8>	Mac Address	Binary Value
<4>	IP Address	Binary Address
<2>	UDP Port	0-32767
<8>	Destination Mac Address	Binary Value
<4>	Destination IP Address	Binary Value
<2>	Destination UDP Port	Binary Value
<1>	Ethernet Mode	0 = UDP 1 = COP3 2 = COP3 FEC
<1>	Block Aligned	0 = Aligned 1 = Not Aligned
<1>	FEC Column L	Binary Value
<1>	FEC Column D	Binary Value

Opcode: <2B51> Set Terrestrial Gig Ethernet Stats

Response		
<1>	Clear Ethernet Stats	0

Opcode: <2440h> Query Test Status

Response		
<1>	Test Pattern	0 = none, 1 = $(2^{15} - 1)$, 23 = $(2^{23} - 1)$
<1>	Test Sync	0 = false, 1 = true
<1>	Test Early Sync Loss	0 = false, 1 = true
<1>	Test Pattern Sense	0 = normal, 1 = inverted
<8>	Test Pattern Error Count	bits
<8>	Test Bit Count	bits
<2>	Test Pattern BER Mantissa	with implied decimal point 493 = 4.93
<2>	Test Pattern BER Exponent	exponent, -6 = 10^{-6}
<4>	Test Run Time	seconds

Opcode: <2A00h> Set Configuration

		Same as <i>Configuration Bytes</i> from Opcode: <2401h> Query Configuration and Status
--	--	--

Opcode: <2A01h> Set frequency

<4>	Carrier Frequency	in 1 Hz steps, If range = 50 MHz to 180 MHz, L-Band Range = 950 MHz to 2150 MHz
-----	-------------------	---

Opcode: <2A02h> Set data rate

<4>	Data Rate	in 1 bps steps
-----	-----------	----------------

Opcode: <2A04h> Set acquisition range

<4>	Acquisition Range	in 1 Hz steps, Max = 7.5 MHz, Min: Symbol rate/10 and when demodulation is 8PSK min: Symbol rate/20
-----	-------------------	---

Opcode: <2A07h> Set demodulation

<1>	Demodulation	0 = QPSK, 2 = 8PSK, 3 = 16QAM, 4 = 16APSK
-----	--------------	---

Opcode: <2A08h> Set inner FEC rate

<1>	Inner FEC Rate	1 = 1/2 Rate, 2 = 2/3 Rate, 3 = 3/4 Rate, 4 = 5/6 Rate, 5 = 7/8 Rate, 8 = 8/9 Rate, 9 = 9/10, 10 = 10/11 Rate, 11 = 11/12 Rate, 12 = 3/5, 13 = 4/5, 14 = 6/7 Rate, 15 = Reserved, 16 = Reserved, 17 = Reserved
-----	----------------	--

Opcode: <2A0Bh> Set network specification

<1>	Network Specification	0 = DVB 1 = DVB-S2 2 = DirecTV AMC
-----	-----------------------	------------------------------------

Opcode: <2A0Fh> Set spectral inversion

<1>	Spectral Inversion	2 = Auto
-----	--------------------	----------

Opcode: <2A10h> Set buffer size

<1>	Buffer size	Milliseconds, Range = 0 msec to 64 msec
-----	-------------	---

Opcode: <2A11h> Set Rx Clock Source

<1>	Rx Clock Source	3 = RX SAT, 4 = EXC direct, 5 = EXC Referenced PLL
-----	-----------------	--

Opcode: <2A12h> Set Rx Clock Polarity

<1>	Rx Clock Polarity	0 = normal, 1 = inverted
-----	-------------------	--------------------------

Opcode: <2A13h> Set Satellite Framing

<1>	Satellite Framing	0 = normal, 1 = short
-----	-------------------	-----------------------

Opcode: <2A17h> Set PRBS test pattern

<1>	Test Pattern	0 = none, 1 = $(2^{15} - 1)$, 23 = $(2^{23} - 1)$
-----	--------------	--

Opcode: <2A1Fh> Set terrestrial interface type

<1>	Interface	0 = RS422 Serial, 2 = ASI, 3 = AASI, 4=G703E3 UNBAL, 5=G703T3 UNBAL, 6=G703STS1 UNBAL, 7= HSSI, 8 = DVB Parallel, 9 = M2P Parallel, 10 = ECL BAL/UNBAL, 11 = Gig Ethernet
-----	-----------	---

Opcode: <2A20> Center Buffer

	No Parameters	
--	---------------	--

Opcode: <2A21h> Set data polarity

<1>	Data Polarity	0 = normal, 1 = inverted
-----	---------------	--------------------------

Opcode: <2A40h> Set framing mode

<1>	Framing Mode	0 = 188 byte, 1 = 204 byte, 2 = no framing
-----	--------------	--

Opcode: <2A41h> Set Nyquist roll off

<1>	Nyquist roll off	0 = 0.35, 20=0.20, 25 = 0.25
-----	------------------	------------------------------

Opcode: <2A43h> Set symbol rate

<1>	Symbol Rate	in 1 symbol steps
-----	-------------	-------------------

Opcode: <2A44h> Set terrestrial streaming

<1>	Terrestrial Streaming	0 = burst packets, 1=continuous bytes
-----	-----------------------	---------------------------------------

Opcode: <2A45h> Clear Events

	No Parameters	
--	---------------	--

Opcode: <2A46h> Reset test

	No Parameters	
--	---------------	--

Opcode: <2C03h> Clear latched alarms

	No Parameters	
--	---------------	--

Opcode: <2C04h> Set time

<1>	Hour	0 – 23
<1>	Minute	0 – 59
<1>	Second	0 – 59

Opcode: <2C05h> Set date

<1>	Year	00 – 99
<1>	Month	0 – 11
<1>	Day	0 – 31

4.4 Ethernet Port User Interface

The Ethernet Port of the DD240 allows for complete control and monitoring of all DD240 parameters and functions via a 10BaseT or 100BaseT Ethernet Connection.

4.5 DD240XR Management Information Base (MIB)

All of the necessary information for the user interface is contained in the DD240 Management Information Base (MIB), which is contained below.

```
--
-----
-- Module       : DemodMib.txt   Project Name: dd240-dvb
-- Start Date   :                Release    :
-- Latest Revision Date: 12/20/01
-- Author(s)    : F. Munoz
--
-- Module Organization:
-- This is a PRELIMINARY document whose contents are subject to change
-- without prior notice.
-- Radyne user MIB Object Identifiers description. The private enterprise
-- number 2591 is a unique identifier assigned to Radyne by the Internet
-- Assigned Numbers Authority (IANA). This number is used to uniquely
-- define vendor specific information such as private MIBs.
--
-- Program Units : (list of program units)
--
-- Requirements Trace : (document(s) and paragraph reference)
--
-- Deviations      : (any deviations from the coding standard)
--
-- Revision History : adapted from dd240 front panel organization
-----
```

RADYNE-DD240-MIB DEFINITIONS ::= BEGIN

```
IMPORTS
    enterprises
        FROM RFC1155-SMI
    TEXTUAL-CONVENTION
        FROM SNMPv2-TC
    OBJECT-TYPE
        FROM RFC-1212;

-- groups in Radyne specific MIB

radyne      OBJECT IDENTIFIER ::= { enterprises 2591 }
dd240-dvb   OBJECT IDENTIFIER ::= { radyne 9 }

demodulator OBJECT IDENTIFIER ::= { dd240-dvb 1 }
interface   OBJECT IDENTIFIER ::= { dd240-dvb 2 }
monitor     OBJECT IDENTIFIER ::= { dd240-dvb 3 }
alarms      OBJECT IDENTIFIER ::= { dd240-dvb 4 }
system      OBJECT IDENTIFIER ::= { dd240-dvb 5 }
test        OBJECT IDENTIFIER ::= { dd240-dvb 6 }
traps       OBJECT IDENTIFIER ::= { dd240-dvb 7 }
```

```
-----
RadPowerLevel ::= TEXTUAL-CONVENTION
    DISPLAY-HINT "d-1"
    STATUS current
    DESCRIPTION
        "Power level in tenths of a dBm."
    SYNTAX INTEGER
```

```
RadRatio ::= TEXTUAL-CONVENTION
    DISPLAY-HINT "0a/0a"
    STATUS current
    DESCRIPTION
        "
        A string which consists of two tokens separated by delimiting character, '/".
```

The first token will be converted into decimal based numerator.
 The second token will be converted into a decimal based denominator.

"
 SYNTAX OCTET STRING (SIZE (20))

```
RadString ::= TEXTUAL-CONVENTION
  DISPLAY-HINT "255a"
  STATUS current
  DESCRIPTION
    "ASCII String."
  SYNTAX OCTET STRING
```

```
RadVoltageLevel ::= TEXTUAL-CONVENTION
  DISPLAY-HINT "d-1"
  STATUS current
  DESCRIPTION
    "Voltage level in tenths of a volt."
  SYNTAX INTEGER
```

 -- demodulator

networkSpec OBJECT-TYPE

```
SYNTAX INTEGER {
  dvb(1),
  dvbS2BsNbc(2),
  dtvAmcNbc(3)
}
```

MAX-ACCESS read-write

STATUS current

DESCRIPTION

"
 Selects network specification.

::= { demodulator 1 }

frequency OBJECT-TYPE

```
SYNTAX Unsigned32 (50000000..180000000|950000000..2150000000)
```

MAX-ACCESS read-write

STATUS current

DESCRIPTION

"
 Selects frequency in Hz.
 I-F valid values are: 50000000..180000000
 L-Band valid values are: 950000000..2150000000
 "

::= { demodulator 2 }

modulation OBJECT-TYPE

```
SYNTAX INTEGER {
```

```
  bpsk(2),
  qpsk(4),
  psk8(8),
  qam16(16)
  apsk16(32)
}
```

MAX-ACCESS read-write

STATUS current

DESCRIPTION

"
 Selects the modulation type.
 Changing modulation type will affect the symbol rate and data rate,
 the IFEC may also be constrained or altered based upon modulation choices.
 "

::= { demodulator 3 }

innerFecRate OBJECT-TYPE

```

SYNTAX INTEGER {
  none(0),
  viterbi1_2(1),
  viterbi2_3(2),
  viterbi3_4(3),
  viterbi4_5(4),
  viterbi5_6(5),
  viterbi6_7(6),
  viterbi7_8(7),
  viterbi8_9(8),
  viterbi9_10(9),
  viterbi10_11(10),
  viterbi11_12(11),
  viterbi3_5(12),
  viterbi4_5(13),
  viterbi6_7(14)
  viterbi1_4(15),
  viterbi1_3(16),
  viterbi2_5(17)
}
MAX-ACCESS read-write
STATUS current
DESCRIPTION
"
  Selects Inner FEC code rate type.
  Changing the encoder will affect symbol rate and data rate.
  Valid values include:
    QPSK - viterbi1_2(1), viterbi2_3(2), viterbi3_4(3), viterbi5_6(5), viterbi7_8(7)
    8PSK - viterbi2_3(2), viterbi5_6(5), viterbi8_9(8)
    16QAM - viterbi3_4(3), viterbi7_8(7)
  Unsupported choices include:
    none(0), viterbi4_5(4),viterbi6_7(6), viterbi9_10(9),viterbi10_11(10),viterbi11_12(11)
    viterbi1_4(15), viterbi1_3(16), viterbi2_5(17)
"
 ::= { demodulator 4 }

-- outerFecRate OBJECT-TYPE
-- SYNTAX RadRatio
-- MAX-ACCESS read-write
-- STATUS optional
-- DESCRIPTION
-- "
--   OID Reserved -- for the Outer FEC ratio
-- "
 ::= { demodulator 5 }
--
-- outerFecBypass OBJECT-TYPE
-- SYNTAX INTEGER {
--   disable(0),
--   enable(1)
-- }
-- MAX-ACCESS read-write
-- STATUS optional
-- DESCRIPTION
-- "
--   OID Reserved -- disables or enables the Reed-Solomon decoder
-- "
 ::= { demodulator 6 }
--
-- scrambler OBJECT-TYPE
-- SYNTAX INTEGER {
--   none(0),
--   ibs(1),
--   v35less(2),
--   v35Ccitt(3),
--   v35EfData(4),
--   v35Fairchild(5),

```

```

-- v35Om73(6),
-- rs(7),
-- rsEfData(8),
-- dvb(9)
-- }
-- MAX-ACCESS read-write
-- STATUS optional
-- DESCRIPTION
-- "
--   Reserved -- selects a scrambler type
-- "
-- ::= { demodulator 7 }
--
-- interleaver OBJECT-TYPE
-- SYNTAX INTEGER ( 15|29|30|58 )
-- MAX-ACCESS read-write
-- STATUS optional
-- DESCRIPTION
-- "
--   Reserved -- selects an interleave branch count
-- "
-- ::= { demodulator 8 }
--
-- interleaverBypass OBJECT-TYPE
-- SYNTAX INTEGER {
--   disable(0),
--   enable(1)
-- }
-- MAX-ACCESS read-write
-- STATUS optional
-- DESCRIPTION
-- "
--   Reserved -- Disables/enables the interleaver.
-- "
-- ::= { demodulator 9 }

dataRate OBJECT-TYPE
  SYNTAX Unsigned32
  MAX-ACCESS read-write
  STATUS current
  DESCRIPTION
  "
  Selects the data rate in bps.
  The data rate may be constrained to specific values, depending
  upon the terrestrial interface installed.
  The data rate and the symbol rate are co-dependent and must both
  stay within the operational parameters of the demodulator.
  "
  ::= { demodulator 10 }

symbolRate OBJECT-TYPE
  SYNTAX Unsigned32
  MAX-ACCESS read-write
  STATUS current
  DESCRIPTION
  "
  Selects the symbol rate in sps.
  The symbol rate may be constrained to specific values, depending
  upon the terrestrial interface installed.
  The data rate and the symbol rate are co-dependent and must both
  stay within the operational parameters of the demodulator.
  "
  ::= { demodulator 11 }

spectrum OBJECT-TYPE
  SYNTAX INTEGER {
    autoDetect(0),

```

```

    normal(1),
    inverted(2)
}
MAX-ACCESS read-write
STATUS current
DESCRIPTION
"
    Inverts the symbol mapping direction of rotation
"
::= { demodulator 12 }

rolloff OBJECT-TYPE
SYNTAX INTEGER ( 20|25|35 )
MAX-ACCESS read-write
STATUS current
DESCRIPTION
"
    '20' selects alpha factor rolloff of 0.20,
    '25' selects alpha factor rolloff of 0.25,
    '35' selects alpha factor rolloff of 0.35
"
::= { demodulator 13 }

lastRateCtrl OBJECT-TYPE
SYNTAX INTEGER {
    auto(0),
    symbol(1),
    data(2)
}
MAX-ACCESS read-write
STATUS current
DESCRIPTION
"
    Changes in bandwidth will attempt to pin symbol rate or data rate.
    Both values may change if an operation limit is encountered.
    G.703 terrestrial interfaces may also require this to be set to data(2).
"
::= { demodulator 14 }

acqRange OBJECT-TYPE
SYNTAX INTEGER
MAX-ACCESS read-write
STATUS current
DESCRIPTION
"
    Selects the acquisition range in Hz.
    Max: 7.5MHz
    Min: Symbol Rate/10 and when modulation is 8PSK
    Min: Symbol Rate/20
"
::= { demodulator 15 }

lnbPower OBJECT-TYPE
SYNTAX INTEGER {
    off(0),
    on(1)
}
MAX-ACCESS read-write
STATUS current
DESCRIPTION
"
    Disables/enables the power provided to the LNB from the demodulator.
"
::= { demodulator 16 }

ebnoFloor OBJECT-TYPE
SYNTAX INTEGER (100..1500)

```

```

MAX-ACCESS read-write
STATUS current
DESCRIPTION
"
    Ebno floor limit in db from 01.00 to 15.00. There is an implied decimal point.
    Example: a value of 1234 represents a floor limit of +12.34 dB
"
 ::= { demodulator 17 }

radPilotSymbolsEnabled OBJECT-TYPE
    SYNTAX INTEGER {
        withoutPilots(0),
        withPilots(1)
    }
    ACCESS read-write
    STATUS current
    DESCRIPTION
        "Enables Pilots in DVB-S2."
    ::= { demodulator 18 }

radPIHeaderScramSeqIndex OBJECT-TYPE
    SYNTAX INTEGER (0..999)
    ACCESS read-write
    STATUS current
    DESCRIPTION
        "Selects PL Scrambler index."
    ::= { demodulator 19 }

radGoldSeqIndex OBJECT-TYPE
    SYNTAX INTEGER (0..262142)
    ACCESS read-write
    STATUS current
    DESCRIPTION
        "Selects Gold Code index."
    ::= { demodulator 20 }

radSatFraming OBJECT-TYPE
    SYNTAX INTEGER {
        no_sat_framing(0),
        sat_framing_96k(1),
        sat_framing_1_5(2),
        sat_framing_dvb(3),
        sat_framing_dss_directpc(4),
        sat_framing_dss_directv(5),
        sat_framing_normal(6),
        sat_framing_short(7),
    }
    MAX-ACCESS read-write
    STATUS current
    DESCRIPTION
        "
            Determines satellite framing
        "
    ::= { demodulator 21 }

```

-- interface

```

interfaceType OBJECT-TYPE
    SYNTAX INTEGER {
        none(0),
        asi(1),
        aasi(2),
        hssi(3),
        rs422Serial(4),
        v35Serial(5),
    }

```

```

parallel(6),
parallelM2P(7),
parallelDVB(8),
g703_E3(9),
g703_T3(10),
g703_E2(11),
g703_T2(12),
g703_T2Balanced(13),
g703_E1Balanced(14),
g703_E1(15),
g703_T1_AMI_BALANCED(16),
g703_T1_B8ZS_BALANCED(17),
g703sts_1(18),
oc3(19),
stm1(20),
directv(21),
directpc(22),
eclBalancedUnbalanced(23),
gigEthernet(24)
}
MAX-ACCESS read-write
STATUS current
DESCRIPTION
"
    Selects the various interface types.
    Only some interface cards have multiple types and these cards will
    allow selections only within their capability.
"
::= { interface 1 }

terrFraming OBJECT-TYPE
SYNTAX INTEGER {
    framing_None(187),
    framing_188_Byte(188),
    framing_204_Byte(204)
}
MAX-ACCESS read-write
STATUS current
DESCRIPTION
"
    '187' byte -- unframed transport stream input.
    '188' byte DVB -- framed transport stream input,
    '204' byte DVB -- framed transport stream input,
    Changing the framing mode will effect the symbol rate and/or data rate.
"
::= { interface 2 }

terrStreaming OBJECT-TYPE
SYNTAX INTEGER {
    packet(1),
    continuous(2)
}
MAX-ACCESS read-write
STATUS current
DESCRIPTION
"
    '1' packet mode is the default interface method of dvb transmissionselects (187 Byte) unframed transport
    stream input.
    '2' continuous byte output -- bytes are transmitted as they are received, this provides an evenly spaced byte
    gap
    This parameter may only be available on some interfaces and some interface types.
"
::= { interface 3 }

-- terrByteGap OBJECT-TYPE
-- SYNTAX Unsigned32 (0..255)
-- MAX-ACCESS read-write

```

```

-- STATUS current
-- DESCRIPTION
-- "
--   Reserved -- will specify inter byte gap when terrStreaming is set to continuous
--   0 indicates even byte spacing, the range of values excepted is dependent upon the data rate
-- "
-- ::= { interface 4 }
--
dataPolarity OBJECT-TYPE
  SYNTAX INTEGER {
    normal(1),
    inverted(2)
  }
  MAX-ACCESS read-write
  STATUS current
  DESCRIPTION
  "
  Selects data polarity
  "
  ::= { interface 5 }

clockPolarity OBJECT-TYPE
  SYNTAX INTEGER {
    normal(1),
    inverted(2)
  }
  MAX-ACCESS read-write
  STATUS current
  DESCRIPTION
  "
  Selects clock polarity for the input buffer clock.
  "
  ::= { interface 6 }

buffClockSource OBJECT-TYPE
  SYNTAX INTEGER {
    rxSat (0),
    excRefPll(1),
    excDir (2)
  }
  MAX-ACCESS read-write
  STATUS current
  DESCRIPTION
  "
  Selects buffer clock source
  "
  ::= { interface 7 }

excRefClock OBJECT-TYPE
  SYNTAX INTEGER (
    1000000 |
    1544000 |
    2000000 |
    2048000 |
    5000000 |
    6312000 |
    8448000 |
    10000000
  )
  MAX-ACCESS read-write
  STATUS current
  DESCRIPTION
  "
  Selects the external clock frequency.
  1 Mhz
  1.544 Mhz => DS1
  2 Mhz
  "

```

```

2.048 Mhz => DS1B
5 Mhz
6.312 Mhz => DS2
8.448 Mhz => DS2B
10 Mhz
"
::= { interface 8 }

rxBufferSize OBJECT-TYPE
SYNTAX INTEGER (0..64)
MAX-ACCESS read-write
STATUS current
DESCRIPTION
"
    Selects the buffer size in mSecs. 0 turns the buffering off
"
::= { interface 9 }

rxBufferReset OBJECT-TYPE
SYNTAX INTEGER {
    ignore(0),
    perform(1)
}
MAX-ACCESS read-write
STATUS current
DESCRIPTION
"
    When a perform(1) is sent the buffer clock will be recentered
"
::= { interface 10 }

radTerrEthMode OBJECT-TYPE
SYNTAX INTEGER {
    udp(0),
    cop3(1),
    cop3_fec(2)
}
ACCESS read-write
STATUS current
DESCRIPTION
    "Selects mode for the Gig Ethernet card."
::= { interface 11 }

radTerrEthIpAddr OBJECT-TYPE
SYNTAX IpAddress
ACCESS read-write
STATUS current
DESCRIPTION
    "Selects the IP address for the Gig Ethernet card."
::= { interface 12 }

radTerrEthUdpPort OBJECT-TYPE
SYNTAX INTEGER (0..65535)
ACCESS read-write
STATUS current
DESCRIPTION
    "Selects the UDP port for the Gig Ethernet card."
::= { interface 13 }

radTerrEthIpAddrDest OBJECT-TYPE
SYNTAX IpAddress
ACCESS read-write
STATUS current
DESCRIPTION
    "Selects the destination IP address for the Gig Ethernet card."
::= { interface 14 }

```

```
radTerrEthUdpPortDest OBJECT-TYPE
  SYNTAX INTEGER (0..65535)
  ACCESS read-write
  STATUS current
  DESCRIPTION
    "Selects the destination UDP port for the Gig Ethernet card."
  ::= { interface 15 }
```

```
radTerrEthBlkMode OBJECT-TYPE
  SYNTAX INTEGER {
    aligned(0),
    notAligned(1)
  }
  ACCESS read-write
  STATUS current
  DESCRIPTION
    "Selects block align mode for the Gig Ethernet card."
  ::= { interface 16 }
```

```
radTerrEthFecColL OBJECT-TYPE
  SYNTAX INTEGER (4..20)
  ACCESS read-write
  STATUS current
  DESCRIPTION
    "Selects FEC Column L for the Gig Ethernet card."
  ::= { interface 17 }
```

```
radTerrEthFecColD OBJECT-TYPE
  SYNTAX INTEGER (4..20)
  ACCESS read-write
  STATUS current
  DESCRIPTION
    "Selects FEC Column D for the Gig Ethernet card."
  ::= { interface 18 }
```

-- monitor

```
eventsReset OBJECT-TYPE
  SYNTAX INTEGER {
    ignore(0),
    perform(1)
  }
  MAX-ACCESS read-write
  STATUS current
  DESCRIPTION
    "
    When a perform(1) is sent the event buffer will be cleared
    "
  ::= { monitor 1 }
```

```
plus5Volts OBJECT-TYPE
  SYNTAX RadVoltageLevel (0..255)
  MAX-ACCESS read-only
  STATUS current
  DESCRIPTION
    "
    +5V monitor with implied decimal point.
    Example: a value of 51 represents +5.1 Volts.
    "
  ::= { monitor 2 }
```

```
plus12Volts OBJECT-TYPE
  SYNTAX RadVoltageLevel (0..255)
  MAX-ACCESS read-only
  STATUS current
  DESCRIPTION
```

```

"
+12V monitor with implied decimal point.
Example: a value of 119 represents +11.9 Volts.
"
::= { monitor 3 }

minus12Volts OBJECT-TYPE
SYNTAX RadVoltageLevel (-255..0)
MAX-ACCESS read-only
STATUS current
DESCRIPTION
"
-12V monitor with implied decimal point.
Example: a value of -122 represents -12.2 Volts.
"
::= { monitor 4 }

plus24Volts OBJECT-TYPE
SYNTAX RadVoltageLevel (0..512)
MAX-ACCESS read-only
STATUS current
DESCRIPTION
"
+24V monitor with implied decimal point.
Example: a value of 242 represents +24.2 Volts.
"
::= { monitor 5 }

spectrumStatus OBJECT-TYPE
SYNTAX INTEGER {
normal(1),
inverted(2)
}
MAX-ACCESS read-only
STATUS current
DESCRIPTION
"
Inverts the symbol mapping direction of rotation.
"
::= { monitor 6 }

lastRateCtrlStatus OBJECT-TYPE
SYNTAX INTEGER {
symbol(1),
data(2)
}
MAX-ACCESS read-only
STATUS current
DESCRIPTION
"
Last rate control can be set to auto, symbol or data, this
value indicates what is actually being used
"
::= { monitor 7 }

inputLevel OBJECT-TYPE
SYNTAX RadPowerLevel (-1000..0)
MAX-ACCESS read-only
STATUS current
DESCRIPTION
"
Signal input level detected by the demodulator, in tenth of a dBm.
Example: a value of -740 represents an input level of -74.0 dBm
"
::= { monitor 8 }

ebnoValidity OBJECT-TYPE

```

SYNTAX INTEGER {

invalidEbno(1),
 validEbno(2),
 belowRange(3),
 aboveRange(4)

}

MAX-ACCESS read-only

STATUS current

DESCRIPTION

"

Indicates a Ebno estimates validity.
 validEbno indicates the value is within range.
 The other values indicate that the ebno estimate is invalid.

"

::= { monitor 9 }

ebnoEstimate OBJECT-TYPE

SYNTAX INTEGER (100..1500)

MAX-ACCESS read-only

STATUS current

DESCRIPTION

"

Ebno floor limit in db from 01.00 to 15.00. There is an implied decimal point.
 Example: a value of 1234 represents a floor limit of +12.34 dB

"

::= { monitor 10 }

frequencyOffset OBJECT-TYPE

SYNTAX INTEGER (-25000000..25000000)

MAX-ACCESS read-only

STATUS current

DESCRIPTION

"

Offset from the selected center frequency in Hz.

"

::= { monitor 11 }

symbolRateOffset OBJECT-TYPE

SYNTAX INTEGER (-10000..10000)

MAX-ACCESS read-only

STATUS current

DESCRIPTION

"

Offset from the selected symbol rate in Hz.

"

::= { monitor 12 }

berEstimateMantissa OBJECT-TYPE

SYNTAX INTEGER (0..100)

MAX-ACCESS read-only

STATUS current

DESCRIPTION

"

The estimated Bit Error Rate after the outside forward error correction has been applied.
 This number is actually the mantissa, M, of the equation $M \times 10^{\text{exp}}$.
 There is an implied decimal point.

Example: a value of 12 represents a $1.2 \times 10^{\text{exp}}$
 Extended Example: a mantissa value of 27 and an exponent value of -34 indicates 2.7×10^{-34}

"

::= { monitor 13 }

berEstimateExponent OBJECT-TYPE

SYNTAX INTEGER (-100..100)

MAX-ACCESS read-only

STATUS current

DESCRIPTION

```

"
The estimated Bit Error Rate after the outside forward error correction has been applied.
This number is actually the exponent, exp, of the equation  $M \times 10^{\text{exp}}$ .
There is an implied decimal point.

Example: a value of -3 represents a  $M \times 10^{-3}$ 
Extended Example: a mantissa value of 27 and an exponent value of -34 indicates 2.7E-34
"
::= { monitor 14 }

rxBufferLevel OBJECT-TYPE
SYNTAX INTEGER (0..100)
MAX-ACCESS read-only
STATUS current
DESCRIPTION
"
The percentage full value of the receive buffer.
There is an implied decimal point.

Example: a value of 94 represents 94% full.
"
::= { monitor 15 }

radTerrEthPortStatus OBJECT-TYPE
SYNTAX INTEGER {
    down(0),
    unresolved(1),
    half_10m(2),
    half_100m(3),
    full_10m(4),
    full_100m(5),
    half_1gig(6),
    full_1gig(7)
}
ACCESS read-only
STATUS current
DESCRIPTION
"Shows the link status of the active Gig Ethernet card."
::= { monitor 16 }

radTerrEthTotalPkts OBJECT-TYPE
SYNTAX Counter32
ACCESS read-only
STATUS current
DESCRIPTION
"Total packet count for the Gig Ethernet card."
::= { monitor 17 }

radTerrEthFecColPkts OBJECT-TYPE
SYNTAX Counter32
ACCESS read-only
STATUS current
DESCRIPTION
"FEC column packet count for the Gig Ethernet card."
::= { monitor 18 }

radTerrEthClrStats OBJECT-TYPE
SYNTAX INTEGER {
    toggle0(0),
    toggle1(1)
}
ACCESS read-write
STATUS current
DESCRIPTION
"Clears the Gig Ethernet card statistics."
::= { monitor 19 }

```

```

-----
-- alarms

majorAlarms OBJECT-TYPE
SYNTAX BITS {
    signalLock(0),
    synthPLL(1),
    inputLevel(2),
    clockActivity(3),
    carrierCommunication(4),
    demodCommunication(5),
    fpgaConfiguration(6)
}
MAX-ACCESS read-only
STATUS current
DESCRIPTION
"
    A bit field. On startup, the agent initializes these to a '0'B value.
"
 ::= { alarms 1 }

majorAlarmsAllowed OBJECT-TYPE
SYNTAX BITS {
    signalLock(0),
    synthPLL(1),
    inputLevel(2),
    clockActivity(3),
    carrierCommunication(4),
    demodCommunication(5),
    fpgaConfiguration(6)
}
MAX-ACCESS read-write
STATUS current
DESCRIPTION
"
    A bit field. Major alarms allowed.
"
 ::= { alarms 2 }

minorAlarms OBJECT-TYPE
SYNTAX BITS {
    dataActivity(0),
    buffUnderflow(1),
    buffNearEmpty(2),
    buffNearFull(3),
    buffOverflow(4),
    excClock(5),
    excPllLock(6),
    demodLock(7),
    ifecLock(8),
    ofecLock(9),
    frameSync(10),
    ebno(11),
    terrEthDestIp(12),
    terrEthLinkStatus(13)
}
MAX-ACCESS read-only
STATUS current
DESCRIPTION
"
    A bit field. On startup, the agent initializes these to a '0'B value.
"
 ::= { alarms 3 }

minorAlarmsAllowed OBJECT-TYPE
SYNTAX BITS {
    dataActivity(0),

```

```

buffUnderflow(1),
buffNearEmpty(2),
buffNearFull(3),
buffOverflow(4),
excClock(5),
excPllLock(6),
demodLock(7),
ifecLock(8),
ofecLock(9),
frameSync(10),
ebno(11),
terrEthDestIp(12),
terrEthLinkStatus(13)
}
MAX-ACCESS read-write
STATUS current
DESCRIPTION
"
    A bit field. Minor alarms allowed.
"
 ::= { alarms 4 }

commonAlarms OBJECT-TYPE
SYNTAX BITS {
    plus5V(0),
    plus12V(1),
    neg12V(2),
    plus24V(3),
    temperature(4),
    lnV(5),
    demodHwFault(6)
}
MAX-ACCESS read-only
STATUS current
DESCRIPTION
"
    A bit field. On startup, the agent initializes these to a '0'B value.

    1 indicates an alarm condition
    temperature(3) is reserved and not currently updated
"
 ::= { alarms 5 }

commonAlarmsAllowed OBJECT-TYPE
SYNTAX BITS {
    plus5V(0),
    plus12V(1),
    neg12V(2),
    plus24V(3),
    temperature(4),
    lnV(5),
    demodHwFault(6)
}
MAX-ACCESS read-write
STATUS current
DESCRIPTION
"
    A bit field. Common alarms allowed.

    temperature(3) is reserved and not currently updated. It is recommended that this
    bit always be disallowed.
"
 ::= { alarms 6 }

latchedMajorAlarms OBJECT-TYPE
SYNTAX BITS {
    signalLock(0),

```

```

synthPLL(1),
inputLevel(2),
clockActivity(3),
carrierCommunication(4),
demodCommunication(5),
fpgaConfiguration(6)
}
MAX-ACCESS read-only
STATUS current
DESCRIPTION
"
  A bit field. On startup, the agent initializes these to a '0'B value.
"
 ::= { alarms 7 }

```

```

latchedMinorAlarms OBJECT-TYPE
SYNTAX BITS {
  dataActivity(0),
  buffUnderflow(1),
  buffNearEmpty(2),
  buffNearFull(3),
  buffOverflow(4),
  excClock(5),
  excPIILock(6),
  demodLock(7),
  ifecLock(8),
  ofecLock(9),
  frameSync(10),
  ebno(11),
  terrEthDestIp(12),
  terrEthLinkStatus(13)
}
MAX-ACCESS read-only
STATUS current
DESCRIPTION
"
  A bit field. On startup, the agent initializes these to a '0'B value.
"
 ::= { alarms 8 }

```

```

latchedCommonAlarms OBJECT-TYPE
SYNTAX BITS {
  plus5V(0),
  plus12V(1),
  neg12V(2),
  plus24V(3),
  temperature(4),
  lnV(5),
  demodHwFault(6)
}
MAX-ACCESS read-only
STATUS current
DESCRIPTION
"
  A bit field. On startup, the agent initializes these to a '0'B value.

  1 indicates an alarm condition
  temperature(3) is reserved and not currently updated
"
 ::= { alarms 9 }

```

```

clearLatchedAlarms OBJECT-TYPE
SYNTAX INTEGER {
  ignore(0),
  perform(1)
}
MAX-ACCESS read-write

```

```

STATUS current
DESCRIPTION
"
  When a perform(1) is sent all the latched alarms will be cleared
"
::= { alarms 10 }
-----
-- system

firmwareRev OBJECT-TYPE
SYNTAX OCTET STRING (SIZE(16))
MAX-ACCESS read-only
STATUS current
DESCRIPTION
"
  Provides the system firmware part and revision, up to 16 ASCII characters
"
::= { system 1 }

radTerrEthRev OBJECT-TYPE
SYNTAX OCTET STRING (SIZE(16))
MAX-ACCESS read-only
STATUS current
DESCRIPTION
  "GigEthernet terrestrial board software revision"
::= { system 2 }

-- revisionNumber OBJECT-TYPE
-- SYNTAX OCTET STRING (SIZE(16))
-- MAX-ACCESS read-only
-- STATUS optional
-- DESCRIPTION
-- "
--   Revision number of the modem MNC firmware with an implied decimal point.
-- "
-- ::= { dd240_System 2 }
--
-----
-- test

testPattern OBJECT-TYPE
SYNTAX INTEGER {
  pattern_none(0),
  pattern_2_15Minus1(15),
  pattern_2_23Minus1(23)
}
MAX-ACCESS read-write
STATUS current
DESCRIPTION
"
  Select a test pattern.
  None will take the unit out of test mode but will not clear the test results.
"
::= { test 1 }

testPatternSync OBJECT-TYPE
SYNTAX INTEGER {
  false(0),
  true(1),
}
MAX-ACCESS read-only
STATUS current
DESCRIPTION
"
  Indicates whether the demodulator is currently synchronized to the test pattern.
"

```

```

 ::= { test 2 }

testEarlySyncLoss OBJECT-TYPE
  SYNTAX INTEGER {
    false(0),
    true(1),
  }
  MAX-ACCESS read-only
  STATUS current
  DESCRIPTION
  "
    Indicates whether the demodulator lost the test pattern synchronization earlier during the test.
  "
 ::= { test 3 }

testPatternSense OBJECT-TYPE
  SYNTAX INTEGER {
    normal(1),
    inverted(2)
  }
  MAX-ACCESS read-only
  STATUS current
  DESCRIPTION
  "
    Indicates whether the test pattern recieved is inverted or not inverted.
  "
 ::= { test 4 }

testBitErrors OBJECT-TYPE
  SYNTAX Counter64
  MAX-ACCESS read-only
  STATUS current
  DESCRIPTION
  "
    Indicates whether the test pattern recieved is inverted or not inverted.
  "
 ::= { test 5 }

testTotalBitCountMantissa OBJECT-TYPE
  SYNTAX INTEGER (0..1000000000)
  MAX-ACCESS read-only
  STATUS current
  DESCRIPTION
  "
    The bit count as measured by the test.
    This number is actually the mantissa, M, of the equation  $M \times 10^{\text{exp}}$ .
    There is an implied decimal point.

    Example: a value of 12345678 represents a  $1.2345678 \times 10^{\text{exp}}$ 
    Extended Example: a mantissa value of 34734782 and an exponent value of 34 indicates  $3.4734782 \times 10^{34}$ 
  "
  bits
 ::= { test 6 }

testTotalBitCountExponent OBJECT-TYPE
  SYNTAX INTEGER (0..100)
  MAX-ACCESS read-only
  STATUS current
  DESCRIPTION
  "
    The bit count as measured by the test.
    This number is actually the exponent, exp, of the equation  $M \times 10^{\text{exp}}$ .
    There is an implied decimal point.

    Example: a value of 3 represents a  $M \times 10^3$ 
    Extended Example: a mantissa value of 34734782 and an exponent value of 34 indicates  $3.4734782 \times 10^{34}$ 
  "
  bits

```

```

"
 ::= { test 7 }

testBitErrorRateMantissa OBJECT-TYPE
SYNTAX INTEGER (0..100)
MAX-ACCESS read-only
STATUS current
DESCRIPTION
"
    The Bit Error Rate as measured by the test.
    This number is actually the mantissa, M, of the equation  $M \times 10^{\text{exp}}$ .
    There is an implied decimal point.

    Example: a value of 12 represents a  $1.2 \times 10^{\text{exp}}$ 
    Extended Example: a mantissa value of 27 and an exponent value of -34 indicates 2.7E-34
"
 ::= { test 8 }

testBitErrorRateExponent OBJECT-TYPE
SYNTAX INTEGER (-100..100)
MAX-ACCESS read-only
STATUS current
DESCRIPTION
"
    The Bit Error Rate as measured by the test.
    This number is actually the exponent, exp, of the equation  $M \times 10^{\text{exp}}$ .
    There is an implied decimal point.

    Example: a value of -3 represents a  $M \times 10^{-3}$ 
    Extended Example: a mantissa value of 27 and an exponent value of -34 indicates 2.7E-34
"
 ::= { test 9 }

testRuntime OBJECT-TYPE
SYNTAX INTEGER (0..1000000000)
MAX-ACCESS read-only
STATUS current
DESCRIPTION
"
    The test runtime in seconds.
"
 ::= { test 10 }

testReset OBJECT-TYPE
SYNTAX INTEGER {
    ignore(0),
    perform(1)
}
MAX-ACCESS read-write
STATUS current
DESCRIPTION
"
    When a perform(1) is sent the test display will be cleared and the the test will restart with the
    selected pattern.
"
 ::= { test 11 }

radTerrEthTestData OBJECT-TYPE
SYNTAX INTEGER {
    stopTest(0),
    startTest(1)
}
ACCESS read-write
STATUS current
DESCRIPTION
    "Selects test mode for the Gig Ethernet card."
 ::= { test 12 }

```

```
-- radTerrEthMacAddr OBJECT-TYPE
--   SYNTAX PhysAddress
--   ACCESS read-write
--   STATUS current
--   DESCRIPTION
--     "Selects the destination test MAC address for the Gig Ethernet card."
--   ::= { test 13 }
```

```
-----
-- traps
```

```
-- Include Prefix for compatibility with SNMPv1 traps and procedures
-- employed by multi-lingual and proxy forwarding systems
```

```
trapsPrefix OBJECT IDENTIFIER ::= { traps 0 }
```

```
majorAlarmTrap NOTIFICATION-TYPE
```

```
  OBJECTS {
    majorAlarms
  }
  STATUS current
  DESCRIPTION "Major alarm trap."
  ::= { trapsPrefix 1 }
```

```
minorAlarmTrap NOTIFICATION-TYPE
```

```
  OBJECTS {
    minorAlarms
  }
  STATUS current
  DESCRIPTION "Minor alarm trap."
  ::= { trapsPrefix 2 }
```

```
commonAlarmTrap NOTIFICATION-TYPE
```

```
  OBJECTS {
    commonAlarms
  }
  STATUS current
  DESCRIPTION "Common alarm trap."
  ::= { trapsPrefix 3 }
```

```
END
```

4.6 Terminal Port User Interface

The Terminal Port of the DD240 is currently only used for upgrade messaging and for manufacturer diagnostics.



Electrical Interfaces

5

5.0 DD240XR Connections

All DD240XR connections are made to labeled connectors located on the rear of the unit. Any connection interfacing to the DD240 must be the appropriate mating connector. The back panel is determined by the options ordered. Refer to Figures 5-1a through 5-1f for connector locations.

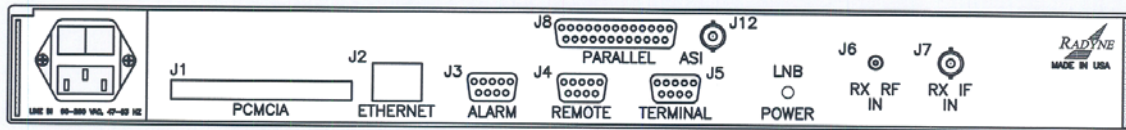

Figure 5-1a. DD240XR Demodulator Rear Panel Connectors (ASI/DVB SPI/MP2P Interface/RS422 Serial (530))

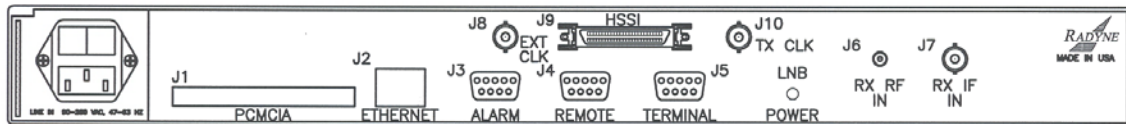

Figure 5-1b. DD240XR Demodulator Rear Panel Connectors (HSSI Interface)

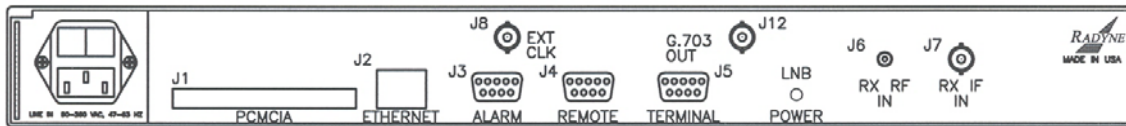

Figure 5-1c. DD240XR Demodulator Rear Panel Connectors (G.703 – E3/DS-3/STS-1 Interface)

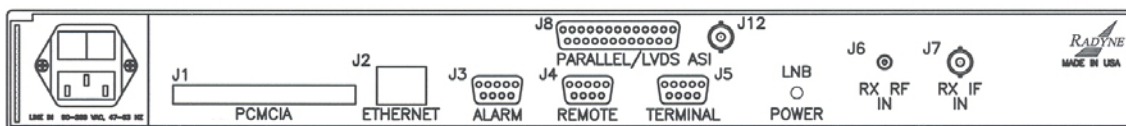

Figure 5-1d. DD240XR Demodulator Rear Panel Connectors (ASI/M2P LVDS Interface)

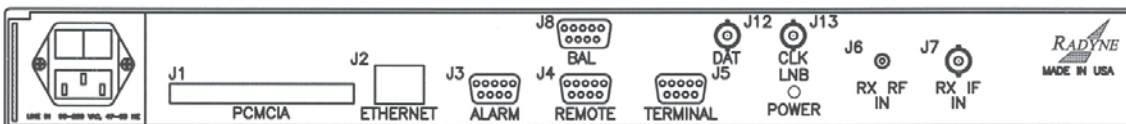

Figure 5-1e. DD240XR Demodulator Rear Panel Connectors (ECL BAL/UNBAL)

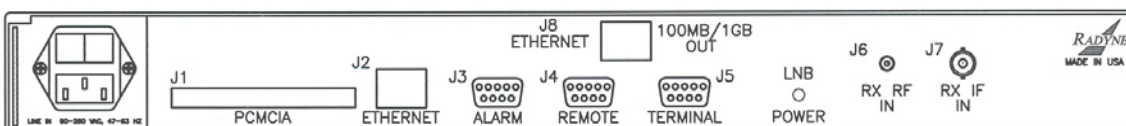

Figure 5-1f. DD240XR Demodulator Rear Panel Connectors (Ethernet GiGi)

5.1 AC Power

The unit is powered from a 100 – 240 VAC, 50 – 60 Hz source. Maximum unit power consumption is 16 Watts when not providing power for an external LNB. The switch turns power on and off to the unit. A chassis ground connection can be made at the stud located to the lower right of the AC Power Connector.

5.2 PCMCIA Interface (J1)

The PCMCIA Interface (J1) allows a PCMCIA Card to be inserted for the following three main functions:

- Feature Upgrade
- Firmware Update
- Custom Configuration

5.2.1 Feature Upgrade

If the customer requires feature upgrades such as 8PSK, 16QAM or DVB-S2 operation, contact the Radyne Corporation Sales Department for ordering information.

Once the customer has the Feature Upgrade Card, the following steps are performed:

1. Power off the unit.
2. Install the Feature Upgrade PCMCIA Card into J1.
3. Power on the unit.
4. Status messages will be displayed on the Front Panel. Additionally, the status messages will be sent out to Terminal Interface, J5.
5. The Event LED (yellow) will flash while the feature upgrade is being added. The LED on the back panel (LNB POWER) will also flash during the upgrade process.
6. If the upgrade was successful, the Remote LED (green) will flash and the LNB POWER LED will illuminate without flashing. Proceed to Step 7. If an error is encountered, an error code will be displayed on the display, the Fault LED (red) will flash, and the LNB POWER LED will extinguish. In this case, the upgrade was not successful. If no LED illuminates, the upgrade may not be compatible for the unit. Do not re-power the unit and contact the Radyne Corporation Customer Service Department at (602) 437-9620
7. Power off the unit.
8. Remove the PCMCIA Card.
9. Power on the unit and access the System Menu. Verify that the revisions match the PCMCIA Card's label.

The loaded features will be available the next time the unit is powered on.

5.2.2 Firmware Update

To upgrade the firmware, a Firmware Upgrade PCMCIA Card is required. Follow the instructions from Section 5.2.1 for upgrade.

5.2.3 Custom Configuration Run Card

For a custom configuration, the customer orders a Custom Configuration PCMCIA Card.

Perform the following steps:

1. Power off the unit.
2. Install the Custom Configuration PCMCIA Card.
3. Power the unit on.

The unit will operate in the custom configuration as long as the PCMCIA Card is installed. If the card is removed and power is cycled, the original operation is restored.

5.3 Ethernet Interface (J2)

The Ethernet Interface (J2) can be used for the monitor & control functions of the unit. The physical interface is a standard female RJ-45 Connector. Refer to Section 7.6 for programming details.

5.4 Alarm Port (J3)

The Alarm Connector (J3) is used to indicate the fault condition of the modulator to external equipment. This male 9-Pin D-Sub Connector provides connection to two form-c relays and an open collector output. The user can distinguish between major and minor alarms with the relays. Refer to Table 5-1 for connector pinouts. Table 5-2 below describes the alarm indications.

Pin No.	Connection
1	Relay 1 NC
2	Relay 1 C
3	Relay 1 NO (Major Alarm)
4	Ground
5	No Connect
6	Mod Fault (Open Collector)
7	Relay 2 NC
8	Relay 2 C
9	Relay 2 NO (Minor Alarm)

Table 5-2. Alarm Indications	
Alarm	Pin Description
None	1 – 2 shorted, 7 – 8 shorted, open collector output driven low
Minor	1 – 2 shorted, 8 – 9 shorted, open collector output driven low
Major	2 – 3 shorted, 7 – 8 shorted, open collector output open

5.5 Remote Port (J4)

The Remote Port Interface (J4) can be used for the monitor & control functions of the unit. The physical interface is a female 9-Pin D-Sub Connector. This bi-directional port complies with RS-485 Electrical Specifications. Refer to Section 7.6 for protocol and programming details. Pin outs are listed in Table 5-3.

Table 5-3. J4 - RS-485 Remote Control- 9-Pin 'D' Female			
Pin No.	Signal	Description	Direction
1	Tx (B)	Transmit Data (+)	Output
5	GND	Ground	-
6	Tx (A)	Transmit Data (-)	Output
8	Rx (B)	Receive Data (+)	Input
9	Rx (A)	Receive Data (-)	Input

5.6 Terminal Port (J5)

The Terminal Port Interface (J5) can be used for the monitor & control functions of the unit. The physical interface is a female 9-Pin D-Sub Connector. This bi-directional port complies with RS-232 Electrical Specifications. Refer to Section 4.6 for terminal interface details. The pinouts are listed in Table 5-4.

Table 5-4. J5 - RS-232 Terminal Port - 9-Pin 'D' Female			
Pin No.	Signal Name	Description	Direction
3	TxD	Transmit Data	Output
2	RxD	Receive Data	Input
5	GND	Ground	---

5.7 RX RF IN (L-Band) (J6)

The Receive RF In (L-Band) (J6) Port is the L-Band input for the DD240 L-Band, 950 – 2150 MHz tuning range through a 75Ω Female F-Type Connector.

5.8 RX IF IN (J7)

The RF Port is a 75Ω Female BNC-Type Connector, and the tuning range is 50 – 180 MHz.

5.9 J8 Ports

J8 is the External Clock Input for the G.703 and HSSI Interfaces.

J8 is the Parallel/Serial RS-422 Output for the ASI Interface.

5.9.1 PARALLEL (ASI/DVB SPI or ASI/M2P Interfaces)

M2P/DVB is supported on the DB-25 Female Connector. It complies with RS-422 Electrical Specifications. Refer to Tables 5-5a and 5-5b for pinouts for this connector. The maximum data rate is 157.5 Mbps.

Table 5-5a. J8 – Parallel - 25-Pin Female			
Pin No.	M2P Signal Name	DVB Signal Name	Direction
1	No Signal Present	CLK+	Output
14	No Signal Present	CLK-	Output
2	CLK+	GND	Output
15	CLK-	GND	Output/Ground
3	SYNC+	D7+	Output/Ground
16	SYNC-	D7-	Output
4	VALID+	D6+	Output
17	VALID-	D6-	Output
5	D0+	D5+	Output
18	D0-	D5-	Output
6	D1+	D4+	Output
19	D1-	D4-	Output
7	D2+	D3+	Output
20	D2-	D3-	Output
8	D3+	D2+	Output
21	D3-	D2-	Output
9	D4+	D1+	Output
22	D4-	D1-	Output
10	D5+	D0+	Output
23	D5-	D0-	Output
11	D6+	VALID+	Output
24	D6-	VALID-	Output
12	D7+	SYNC+	Output
25	D7-	SYNC-	Output
13	GND	GND	Ground

Pin No.	DVB Signal Name	Direction
7	GND	Ground
9	CLK+	Output
17	CLK-	Output
16	Data+	Output
3	Data-	Output
1	GND	Output

5.9.2 EXT CLK (HSSI and G.703 Interfaces Only)

The External Clock Input (J8) is supplied to allow the customer to phase-lock the Doppler buffer clock to an external reference. The external reference can be used directly as a buffer clock.

This female BNC Connector accepts a 1.5 – 5 Vp-p @ 50 Ohms. The allowed frequencies are:

1.1 MHz	1.544 MHz	6.312 MHz	5.0 MHz
2.0 MHz	2.048 MHz	8.448 MHz	10.0 MHz

5.9.3 PARALLEL/LVDS (ASI/M2P Interface Only)

This interface is identical to the ASI/Parallel RS-422 Interface except that the electrical specifications of the Parallel Interface (M2P, DVB) comply with LVDS instead of RS-422.

5.10 HSSI Interface (J9) (HSSI Interface Only)

The HSSI (High-Speed Serial Interface) complies with the HSSI Functional and Electrical Specifications. The physical interface is a 50 Pin SCSI-2 Type Connector. Electrical levels are ECL. The pinouts for this interface are listed in Table 5-6.

5.11 TX CLK (J10) (HSSI Interface Only)

This connector is used for the HSSI Interface.

5.12 J12 Ports

5.12.1 ASI (ASI/DVB SPI and ASI/M2P Interfaces Only)

The Asynchronous Serial Interface is supported on the BNC Connector. The interface complies with DVB ASI Electrical Specifications. The maximum data rate is 216 Mbps.

5.12.2 G.703 OUT (G.703 Interface Only)

The G.703 Interface supports three different G.703 rates (E3, DS-3, and STS-1). The physical interface is a single Female BNC Connector. The data rate for the E3 Interface is 34.368 Mbps, 44.736 Mbps for the T3 Interface, and 51.84 Mbps for the STS-1 Interface. The interface complies with G.703 electrical specifications.

5.13 ECL Interface

5.13.1 ECL Balanced (J8)

The ECL Balanced Port (J8) is a female 9-Pin D-Sub Connector. Refer to Table 5-7 for pinouts.

5.13.2 ECL Unbalanced Data (J12)

The ECL Unbalanced Data Interface is a Female BNC Connector.

5.13.3 ECL Unbalanced Clock (J13)

The ECL Unbalanced Clock Interface is a Female BNC Connector.

Table 5-6. J9 – HSSI (High-Speed Serial Interface) 50-Pin Connector				
Pin No. (+)	Pin No. (-)	Signal Name	Description	Direction
1	26	SG	Signal Ground	-
2	27	RT	Receive Timing	Output
3	28	CA	DCE Available	Output
4	29	RD	Receive Data	Output
5	30	LC		Not Used
6	31	ST	Send Timing	N/A
7	32	SG	Signal Ground	-
8	33	TA	DTE Available	N/A
9	34	TT	Terminal Timing	N/A
10	35	LA	Loop back Circuit A	Not Used
11	36	SD	Send Data	N/A
12	37	LB	Loop back Circuit B	Not Used
13	38	SG	Signal Ground	-
15	40	EB CLK	External Bal. Clock	Used as EXT BAL CLK Input
14, 16 - 18	39, 41 – 43	4 Ancillary to DCE		Input
19	44	SG	Signal Ground	-
20 - 22	45 - 47	3 Ancillary from DCE		Output
24	49	TM		Output
25	50			Not Used

Table 5-7. J8 – ECL Balanced 9-Pin Female		
Pin No.	DVB Signal Name	Direction
3	Data B	Output
8	Data A	Output
4	Clock B	Output
9	Clock A	Output
5	GND	Ground

5.14 Ethernet Interface GiGi (J8)

The Gigi Ethernet data interface is a 100/1000 Base T supported by an RJ45 connector. The Ethernet interface supports two protocols, Bridge option and PRO MPEG COP3 output format. PRO MPEG COP 3 (Code of Practice 3) is a powerful video-specific packet-based forward error correction (FEC) algorithm, a cost-effective solution for error recovery in video streams transported over public or private IP networks.

The Gigi Ethernet data interface can also support Bridge option, a Generic Ethernet IP Interface. The Gigi Interface recovers IP traffic from satellite data and outputs the data to local LAN. This feature can be enabled via the front panel by utilizing the Program Ethernet Flash menu.

5.14.1 Gigi Ethernet Data Interface, Additional Menus

When the Gigabit Ethernet Data interfaces are installed, it will add new menus for control and status monitoring. It is recommended that all Ethernet parameters be selected prior to placing the unit into the network.

ETHERNET INTERFACE MENU - When the Ethernet Data Interface is installed, the interface type will reflect the Gigabit Ethernet and cannot be changed. The following items are available under the Ethernet Interface menu

TERR FRAMING: {DVB 188}

When the Ethernet Data Interface is installed, the terrestrial framing is fixed DVB 188 and cannot be changed.

TERR ETHERNET:

This is where the desired MPEG over IP traffic type is selected. The following new items are available under the Terrestrial Ethernet menu:

TERR MAC ADDR: {0123456789AB}

This menu displays the MAC addresses of the Ethernet Data Interface card. Entering any non-zero value in this field will cause the EDI to use the entered value as its MAC address. Entering a value of all zeros will cause the Ethernet Data Interface to revert back to its original MAC address.

MODE SELECTIONS:

UDP PACKETS - the demodulator outputs seven MPEG packets encapsulated in a UDP datagram.

COP 3 RTP - the demodulator outputs seven MPEG packets encapsulated in a COP 3 compliant RTP datagram.

COP 3 RTP FEC - the demodulator outputs COP 3 compliant Column FEC packets in addition to the RTP datagram.

IP ADDR:

{XXX.XXX.XXX.XXX}

This is the IP address to be used by the Ethernet Data Interface. This will be the source IP address for all Ethernet traffic generated by this interface.

UDP PORT:

{XXXXX}

This is the source UDP port to be used by the Ethernet Data Interface.

DEST IP ADDR:

{XXX.XXX.XXX.XXX}

This is the destination IP address that the Ethernet Data Interface will sent all Ethernet traffic to.

**NOTE*****Unicast Destination IP Addresses***

When the destination address is a Unicast address (000.000.000.000 thru 223.255.255.255) the Ethernet Data Interface will use an ARP Request to determine the Destination MAC address to which the data will be sent. This could be the MAC address of the final destination or the MAC address of the first router through which this data will pass. The Ethernet Data Interface will not output any data until it receives an ARP Reply to its ARP Request.

**NOTE*****Multicast Destination IP Addresses***

When the destination address is a Multicast address (224.0.0.0 thru 255.255.255.255) the Ethernet Data Interface will construct the appropriate Destination Multicast MAC address based upon the Destination Multicast IP Address. The Ethernet Data Interface will then transmit multicast data packets to the destination without performing any other handshaking or IGMP message processing.

DEST UDP PORT:	{XXXXX} This is the destination UDP port that the Ethernet Data Interface will send all MPEG traffic to.
BLOCK ALIGNED:	{YES or NO} This menu is only visible when COP 3 RTP FEC is selected. Yes: selects block aligned Column FEC. No: selects non-block aligned Column FEC. Each column is offset by 1, as illustrated in Informative Annex A of COP 3 release 2.
FEC COLUMN L	{X} This menu is only visible when COP 3 RTP FEC is selected. This selects the number of columns used by the FEC.
FEC COLUMN D	{X} This menu is only visible when COP 3 RTP FEC is selected. This selects the number of rows used by the FEC calculation.

**NOTE****Constraints on L and D values**

L and D have the following constraints

$$4 \leq L \leq 20$$

$$4 \leq D \leq 20$$

$$L * D \leq 100$$

PROG ETH FLASH:**{PRESS CLEAR}**

The firmware resident on the EDI card can be updated via PCMCIA card. To upgrade the EDI firmware, install the appropriate PCMCIA card, scroll to this menu, and press clear. The front panel will sequence through a series of displays indicating that the flash is being Erased, Programmed, and Verified. At the end of sequence the final status will be displayed as either Successful or Unsuccessful. The current revision of firmware resident on the EDI card can be accessed via the System menu and is described in detail in that section.

MONITOR - The following new items are available under the Monitor menu

LINK STATUS:**{1 GIG FULL, 100 MEG FULL, NO LINK}**

This menu displays the current terrestrial link status and rate at which the Ethernet Data Interface has established a physical connection.

1 GIG FULL - One Gigabit Full Duplex (1000BaseT)
100 MEG FULL 100 Megabits Full Duplex (100BaseT)
NO LINK - No connection.

TOTAL PACKETS:**{0123456789}**

This menu displays the total number of data packets that have been output by the Ethernet Data Interface. This is either the number of UDP packets in UDP mode, or the number of RTP packets in COP3 RTP and COP3 RTP FEC mode.

FEC PACKETS:**{0123456789}**

This menu is only visible when COP 3 RTP FEC is selected.

This menu displays the total number of FEC packets that have been output by the Ethernet Data Interface in COP3 RTP FEC mode.

CLEAR STATUS:**(ENTER)**

Pressing Enter will reset the Total Packet and FEC Packet counters.

ALARMS - The following new items are available under the Alarms menu

CURRENT ALARMS - The following new items are available under the Current Alarms menu

RX MINOR - The following new items are available under the Rx Minor menu

IP DEST ADDR:**{Pass/Fail, Unmasked/Masked}**

Fail indicates the EDI has not received an ARP reply to its ARP requests and thus has not been able to resolve the destination MAC address.

ETH LINK:**{Pass, Fail, Unmasked/Masked}**

Fail indicates that the Ethernet Data Interface has not been able to establish a valid physical connection on its Ethernet data port.

SYSTEM - The following new items are available under the System menu

HW / FW CONFIG - The following new items are available under the HW / FW Configuration menu

TERR INTFC BRD - The following new items are available under the Terrestrial Interface Board menu

TYPE**{AS5490}**

Indicates the Ethernet Data Interface board assembly number.

BOARD ID**{REV -}**

This indicates the Ethernet Data Interface board revision.

FIRMWARE REV**{FW/5563--}**

This indicates the Ethernet Data Interface firmware revision.

TEST - The following new items are available under the Test menu

ETH DEST MAC**{XXXXXXXXXXXX}**

This field allows the operator to enter a Destination MAC address to be used by the Ethernet Data Interface. When this field is non-zero, the Ethernet Data Interface will use this value for the Destination MAC address instead of trying to resolve the Destination MAC address in the normal manner. When this field is zero, the Ethernet Data Interface will resolve the Destination MAC using ARP for Unicast IP Addresses and automatic construction for Multicast IP Addresses.

ETH TEST DATA**{ENABLED / DISABLED}**

This field allows the operator to test LAN connectivity and routing without requiring an input IF signal for the DD240 to demodulate. When enabled, the Ethernet Data Interface will generate a test MPEG stream at the programmed data rate. This test stream consists of MPEG packets with the following contents:

- Sync byte (0x47)
- Second byte that increments once per MPEG packet
- 186 data bytes that are a running counter that increments each byte across all MPEG packets

The Ethernet Data Interface will lock to this stream as though it were actual demodulated data and generate the appropriate UDP, RTP, and FEC packets depending up the operational mode.



Maintenance

6

6.0 Periodic Maintenance



The DD240XR contains a Lithium Battery. DANGER OF EXPLOSION exists if the battery is incorrectly replaced. Replace only with the same or equivalent type recommended by the manufacturer. Dispose of used batteries in accordance with manufacturers instructions

The DD240XR modulator requires no periodic field maintenance procedures. Should a unit be suspected of a defect in field operations after all interface signals are verified, the correct procedure is to replace the unit with another known working DD240XR. If this does not cure the problem, wiring or power should be suspect.

There is no external fuse on the DD240XR. The fuse is located on the power supply assembly inside the case, and replacement is not intended in the field.



Technical Specifications

7

7.0 Introduction

This section defines the technical performance parameters and specifications for the DD240XR Digital Demodulator.

7.1 L-Band IF Specification

Rx IF:	950 –2150 MHz
IF Step Size:	1 Hz
IF Tuner Accuracy:	±2 kHz
Input Level:	$C_0 + 10 \log(\text{Symbol Rate})$, C_0 : -130 dBm/Hz to 105 dBm Hz -70 to -45 dBm @ 1 Msps -60 to -35 dBm @ 10 Msps -53 to -28 dBm @ 45 Msps
Composite Power:	< -20 dBm total input power
LNB Power:	18 V ± 0.5 V, 350 mA maximum
Input Impedance:	75 Ohm
Return Loss:	7 dB
Input Connector:	F Connector

7.2 Optional 70/140 MHz Specification (includes L-Band)

Rx IF:	50 - 180 MHz
IF Step Size:	1 Hz
IF Tuner Accuracy:	±2 kHz
Input Level:	$C_0 + 10 \log(\text{Symbol Rate})$, C_0 : -130 dBm/Hz to -105 dBm Hz -70 to -45 dBm @ 1 Msps -60 to -35 dBm @ 10 Msps -53 to -28 dBm @ 45 Msps
Composite Power:	< -20 dBm total input power
Input Impedance:	75 Ohm
Return Loss:	15 dB
Input Connector:	BNC Female

7.3 Baseband Specification

Compliance:	EN 300-421 and EN 301-210
Modulation Types:	QPSK, 8PSK, 16QAM
Data Rate:	2 – 78.75 Mbps, 1 bps steps (QPSK, 204 framing) 2 – 120 Mbps, 1 bps steps (8PSK, 204 framing) 3 – 157.5 Mbps, 1 bps steps (16QAM, 204 framing)
Variable Data Rate:	1 – 157.5 Mbps
Step Size:	1 bps
Symbol Rate:	1 – 45 Msps, 1 sps steps
Frame Size:	187 payload bytes, 1 sync byte, 16 parity bytes
Terrestrial Framing:	204, 188, 187 (unframed data)
Baseband Roll-Off:	0.35 Square Root Raised Cosine (QPSK, 8PSK, 16QAM) 0.25 Square Root Raised Cosine (8PSK, 16QAM)

Forward Error Correction (FEC) Decoding

Inner Code: PTCM (8PSK, 16QAM), Viterbi (QPSK)
 Code Rates: 1/2, 2/3, 3/4, 5/6, 7/8 (QPSK)
 2/3, 5/6, 8/9 (8PSK)
 3/4, 7/8 (16QAM)
 Outer Code: Reed-Solomon, Per EN 300-421
 (204, 188, T=8)
 Deinterleaving: Convolutional, l=12, Per EN 300-421
 Data Descrambling: Per EN 300-421
 Terrestrial Framing Modes: 204, 188, 187
 Internal Clock Source Stability: 10 ppm
 Internal Doppler Buffer: 0 – 64 msec, G.703 Interface

7.3.1 DVB-S2-CCM

Compliance: ETSI EN 302 307 v1.1.1 (Broadcast Services Only)
 Modulation Types: QPSK, 8PSK, 16APSK

Data Rate: **Normal FEC Frames:**
 QPSK: 1 to 80 Mbps in 1 bps steps
 8PSK: 3.9 to 120 Mbps in 1 bps steps
 16APSK: 5.3 to 160 Mbps in 1 bps steps

Short FEC Frames:
 QPSK: .75 to 77. Mbps in 1 bps steps
 8PSK: 3.8 to 116 Mbps in 1 bps steps
 16APSK: 5.1 to 153 Mbps in 1 bps steps

Symbol Rate: 2 to 45 Msps in 1 sps steps
 Terrestrial Framing: 188 (1 sync byte, 187 payload bytes)
 Baseband Processing: Per ETSI EN 302 307 v1.1.1
 Block Size: 64.8 Kbits or 16.2 Kbits
 FEC Code: BCH + LDPC
 De-Interleaver: Block Interleaver, per ETSI EN 302 307 v1.1.1
 Inner Code Rate: QPSK - 1/2, 3/5, 2/3, 3/4, 4/5, 5/6, 8/9, 9/10 (Normal Frames)
 8PSK - 3/5, 2/3, 3/4, 5/6, 8/9, 9/10 (Normal Frames)
 16APSK - 2/3, 3/4, 4/5, 5/6, 8/9, 9/10 (Normal Frames)

Baseband Roll-Off: Square Root Raised Cosine
 0.20, 0.25, 0.35

7.4 Configuration Series DVB-S

Series 100: 2 - 10 Msps, QPSK
 Series 200: 2 - 45 Msps, QPSK
 Series 300: 2 - 45 Msps, QPSK / 8PSK
 Series 350: 2 - 45 Msps, QPSK / 8PSK / 16QAM

7.4.1 Configuration Series DVB-S2

Series 100:	2 - 10 Msps, QPSK
Series 200:	2 - 45 Msps, QPSK
Series 300:	2 - 45 Msps, QPSK / 8PSK
Series 350:	2 - 45 Msps, QPSK / 8PSK / 16APSK

7.5 Interface Types Available

ASI/RS-422 Parallel/Serial RS-422:	ASI Serial BNC Female DVB Parallel DB-25 Female M2P Parallel DB-25 Female RS-422 via EIA-530 DB-25 Female
ASI / LVDS Parallel:	ASI Serial BNC Female DVB Parallel DB-25 Female M2P Parallel DB-25 Female
HSSI:	HSSI, Serial, 50-Pin SCSI-2 Type Connector Female
G.703:	G.703 (E3, T3, STS-1), Serial, BNC Female
ECL:	ECL BAL DB-9 Female ECL UNBAL BNC
Ethernet (GiGi) 100/1000 Base-T	Bridge, RJ45 Pro-MPEG COP3, RJ45

7.6 Monitor and Control

Interface:	Serial RS485, Ethernet 10 Base T
Parameters Controlled:	Rx Frequency LNB Power Source Modulation Type FEC Rate Spectral Inversion Data Rate Symbol Rate Roll-Off Interface Type Terrestrial Framing Clock/Data Sources Clock/Data Polarity Buffer Depth Buffer Bypass Test Modes Acquisition Range Eb/No Alarm Limit
Parameters Monitored:	Input Level Eb/No Frequency Offset Symbol Rate Offset Alarms (Major/Minor) Stored Alarms (Major/Minor) Faults Stored Faults

7.7 Environmental

Prime Power 100 to 240 VAC, 50 to 60 Hz, 65 Watts Maximum
 Operating Temperature: 0 to 50° C
 Operating Humidity: Up to 95%, Non-condensing
 Storage Temperature: -20 to 70° C.
 Storage Humidity: Up to 99%, Non-condensing

7.8 Physical

Weight: 7 lb. (3.2 Kg)
 Size: 19" W x 17" D x 1.75" H
 (48.3 x 43.2 x 4.45 cm)

7.9 Options

50Ω IF Output (on 70/140 MHz IF)
 48 VDC Operation

7.10 BER Performance (DVB-S)

Specified IF back-to-back Eb/No Performance:

BER	QPSK					8PSK			16QAM	
	1/2	2/3	3/4	5/6	7/8	2/3	5/6	8/9	3/4	7/8
1.00 x 10 ⁻⁰⁷ (< 20 MSPS)	3.9	4.4	4.9	5.4	5.8	6.3	8.3	8.8	8.4	10.1
1.00 x 10 ⁻⁰⁷ (> 20 MSPS)	3.9	4.5	5.1	5.8	6.4	6.5	8.8	9.8	8.6	11.1
1.00 x 10 ⁻¹⁰ (< 20 MSPS)	4.5	5.0	5.5	6.0	6.4	6.9	8.9	9.4	9.0	10.7
1.00 x 10 ⁻¹⁰ (> 20 MSPS)	4.5	5.1	5.7	6.4	7.0	7.1	9.4	10.4	9.2	11.7

Typical IF back-to back Eb/No Performance

BER	QPSK					8PSK			16QAM	
	1/2	2/3	3/4	5/6	7/8	2/3	5/6	8/9	3/4	7/8
1.00 x 10 ⁻⁰⁷ (< 20 MSPS)	3.1	3.8	4.2	4.6	5.1	5.7	7.5	8.4	7.7	8.7
1.00 x 10 ⁻⁰⁷ (> 20 MSPS)	3.1	4.0	4.3	5.0	5.3	5.7	7.6	9.0	8.0	9.0

7.11 BER Performance (DVB-S2) Per EN 302-307 V1.1.2

Typical IF back-to back Eb/No Performance

BER	QPSK (DVB-S2)							
	1/2	3/5	2/3	3/4	4/5	5/6	8/9	9/10
1.00×10^{-06} (< 20 MSPS)	2.0	2.5	2.7	3.0	3.5	3.8	4.5	4.7
1.00×10^{-06} (> 20 MSPS)	2.0	2.5	2.7	3.0	3.5	3.8	4.5	4.7

BER	8PSK (DVB-S2)					
	3/5	2/3	3/4	5/6	8/9	9/10
1.00×10^{-06} (< 20 MSPS)	4.3	4.6	5.4	6.3	7.3	7.5
1.00×10^{-06} (> 20 MSPS)	4.4	4.7	5.5	6.4	7.4	7.6

BER	16APSK (DVB-S2)				
	2/3	3/4	5/6	8/9	9/10
1.00×10^{-06} (< 20 MSPS)	5.4	6.5	7.3	8.2	8.4
1.00×10^{-06} (> 20 MSPS)	5.5	6.6	7.4	8.3	8.5

7.12 Data Rates (DVB-S)

All Data Rates in Mbps

Series 100 (10 Msps Max)			
Modulation	FEC	MPEG	
		Minimum	Maximum
QPSK	1/2	0.921569	9.215686
QPSK	2/3	1.228758	12.28758
QPSK	3/4	1.382353	13.82352
QPSK	5/6	1.535948	15.35947
QPSK	7/8	1.612745	16.12745

Series 200 (45 Msps Max)			
Modulation	FEC	MPEG	
		Minimum	Maximum
QPSK	1/2	1.843137	41.470588
QPSK	2/3	2.457516	55.294118
QPSK	3/4	2.764706	62.205882
QPSK	5/6	3.071895	69.117647
QPSK	7/8	3.225490	72.573529

Series 300 (45 Msps Max)			
Modulation	FEC	MPEG	
		Minimum	Maximum
QPSK	1/2	1.843137	41.470588
QPSK	2/3	2.457516	55.294118
QPSK	3/4	2.764706	62.205882
QPSK	5/6	3.071895	69.117647
QPSK	7/8	3.225490	72.573529
8PSK	2/3	3.686275	8.2941176
8PSK	5/6	4.607843	103.676471
8PSK	8/9	4.915033	110.588235

Series 350 (45 Msps Max)			
Modulation	FEC	MPEG	
		Minimum	Maximum
QPSK	1/2	1.843137	41.470588
QPSK	2/3	2.457516	55.294118
QPSK	3/4	2.764706	62.205882
QPSK	5/6	3.071895	69.117647
QPSK	7/8	3.225490	72.573529
8PSK	2/3	3.686275	82.941176
8PSK	5/6	4.607843	103.676471
8PSK	8/9	4.915033	110.588235
16QAM	3/4	5.529412	124.411765
16QAM	7/8	6.450980	145.147059

7.13 Data Rates (DVB-S2 with Pilots Off)

Series 100 (10 Msps Max)					
Modulation	FEC	MPEG Frame Size			
		Minimum Long = 64.8K	Maximum Long = 64.8K	Minimum Short = 16.2K	Maximum Short = 16.2K
QPSK	1/2	1.977716	9.888581	1.697680	8.488400
QPSK	2/3	2.644506	12.222530	2.576801	12.884005
QPSK	3/4	2.974946	14.874731	2.840537	14.202686
QPSK	3/5	2.376608	11.883041	2.313065	11.565324
QPSK	4/5	3.174394	15.871961	3.016361	15.081807
QPSK	5/6	3.309326	16.546630	3.192186	15.960928
QPSK	8/9	3.532902	17.664512	3.455922	17.279609
QPSK	9/10	3.577224	17.886119	NA	NA

Series 200 (45 Msps Max)					
Modulation	FEC	MPEG Frame Size			
		Minimum Long = 64.8K	Maximum Long = 64.8K	Minimum Short = 16.2K	Maximum Short = 16.2K
QPSK	1/2	1.977716	44.498615	1.697680	38.197802
QPSK	2/3	2.644506	59.501385	2.576801	57.978022
QPSK	3/4	2.974946	66.936288	2.840537	63.912088
QPSK	3/5	2.376608	53.473684	2.313065	52.043956
QPSK	4/5	3.174394	71.423823	3.016361	67.868132
QPSK	5/6	3.309326	74.459834	3.192186	71.824176
QPSK	8/9	3.532902	79.490305	3.455922	77.758242
QPSK	9/10	3.577224	80.487535	NA	NA

Series 300 (45 Mps Max)					
Modulation	FEC	MPEG Frame Size			
		Minimum Long = 64.8K	Maximum Long = 64.8K	Minimum Short = 16.2K	Maximum Short = 16.2K
QPSK	1/2	1.977716	44.498615	1.697680	38.197802
QPSK	2/3	2.644506	59.501385	2.576801	57.978022
QPSK	3/4	2.974946	66.936288	2.840537	63.912088
QPSK	3/5	2.376608	53.473684	2.313065	52.043956
QPSK	4/5	3.174394	71.423823	3.016361	67.868132
QPSK	5/6	3.309326	74.459834	3.192186	71.824176
QPSK	8/9	3.532902	79.490305	3.455922	77.758242
QPSK	9/10	3.577224	80.487535	NA	NA
8PSK	3/5	3.559982	80.099585	3.450638	77.639344
8PSK	2/3	3.961272	89.128631	3.844080	86.491803
8PSK	3/4	4.456247	100.265560	4.237523	95.344262
8PSK	5/6	4.957123	111.535270	4.762113	107.147541
8PSK	8/9	5.292024	119.070539	5.155556	116.000000
8PSK	9/10	5.358414	120.564315	NA	NA

Series 350 (45 Msps Max)					
Modulation	FEC	MPEG Frame Size			
		Minimum Long = 64.8K	Maximum Long = 64.8K	Minimum Short = 16.2K	Maximum Short = 16.2K
QPSK	1/2	1.977716	44.498615	1.697680	38.197802
QPSK	2/3	2.644506	59.501385	2.576801	57.978022
QPSK	3/4	2.974946	66.936288	2.840537	63.912088
QPSK	3/5	2.376608	53.473684	2.313065	52.043956
QPSK	4/5	3.174394	71.423823	3.016361	67.868132
QPSK	5/6	3.309326	74.459834	3.192186	71.824176
QPSK	8/9	3.532902	79.490305	3.455922	77.758242
QPSK	9/10	3.577224	80.487535	NA	NA
8PSK	3/5	3.559982	80.099585	3.450638	77.639344
8PSK	2/3	3.961272	89.128631	3.844080	86.491803
8PSK	3/4	4.456247	100.265560	4.237523	95.344262
8PSK	5/6	4.957123	111.535270	4.762113	107.147541
8PSK	8/9	5.292024	119.070539	5.155556	116.000000
8PSK	9/10	5.358414	120.564315	NA	NA
16APSK	2/3	5.274401	118.674033	5.097585	114.695652
16APSK	3/4	5.933456	133.502762	5.619324	126.434783
16APSK	4/5	6.331246	142.453039	5.967150	134.260870
16APSK	5/6	6.600368	148.508287	6.314976	142.086957
16APSK	8/9	7.046286	158.541436	6.836715	153.826087
16APSK	9/10	7.134684	160.530387	NA	NA



Glossary



A	
A	Ampere
AC	Alternating Current
ADC	Analog to Digital Converter
AGC	Automatic Gain Control
AIS	Alarm Indication System. A signal comprised of all binary 1s.
AMSL	Above Mean Sea Level
ANSI	American National Standards Institute
ASCII	American Standard Code for Information Interchange
ASIC	Application Specific Integrated Circuit
ATE	Automatic Test Equipment
B	
BCH	Bose-Chaudhuri-Hocquenghem
BER	Bit Error Rate
BERT	Bit Error Rate Test
Bit/BIT	Binary Digit or Built-In Test
BITE	Built-In Test Equipment
bps	Bits Per Second
BPSK	Binary Phase Shift Keying
BUC	Block Upconverter
Byte	8 Binary Digits

C	
C	Celsius
CATS	Computer Aided Test Software
CA/xxxx	Cable Assembly
CCM	Constant Coding and Modulation
CD-ROM	Compact Disk – Read Only Memory
CLK	Clock
cm	Centimeter
COM	Common
CPU	Central Processing Unit
CRC	Cyclic Redundancy Check. A system of error checking performed at the transmitting and receiving stations.
CW	Continuous Wave
C/N	Carrier to Noise Ratio
D	
DAC	Digital to Analog Converter
dB	Decibels
dBc	Decibels Referred to Carrier
dBm	Decibels Referred to 1.0 milliwatt
DC	Direct Current
Demod	Demodulator or Demodulated
DPLL	Digital Phase Locked Loop
DVB	Digital Video Broadcast
D & I	Drop and Insert
E	
E_b/N_0	Ratio of Energy per bit to Noise Power Density in a 1 Hz Bandwidth.
EEPROM	Electrically Erasable Programmable Read Only Memory
EIA	Electronic Industries Association
EMI	Electromagnetic Interference
ESC	Engineering Service Circuits
ES-ES	Earth Station to Earth Station Communication
ET	Earth Terminal

F	
F	Fahrenheit
FAS	Frame Acquisition Sync. A repeating series bits, which allow acquisition of a frame.
FCC	Federal Communications Commission
FEC	Forward Error Correction
FIFO	First In, First Out
FPGA	Field Programmable Gate Arrays
FW	Firmware
G	
g	Force of Gravity
GHz	Gigahertz
GND	Ground
H	
HSSI	High Speed Serial Interface
HW	Hardware
Hz	Hertz (Unit of Frequency)
I	
IBS	Intelsat Business Services
IDR	Intermediate Data Rate
I/O	Input/Output
IEEE	International Electrical and Electronic Engineers
IESS	INTELSAT Earth Station Standards
IF	Intermediate Frequency
INTELSAT	International Telecommunication Satellite Organization
ISO	International Standards Organization
I & Q	Analog In-Phase (I) and Quadrature Signals (Q)
J	
J	Joule
K	
Kbps	Kilobits per Second
Kb/s	Kilobytes per Second
kg	Kilogram
kHz	Kilohertz
Ksps	Kilosymbols per Second

L	
LCD	Liquid Crystal Display
LDPC	Low-Density Parity Check
LED	Light Emitting Diode
LO	Local Oscillator
M	
mA	Milliampere
Mbps	Megabits per Second
MFAS	Multi-Frame Acquisition Sync. See FAS.
MHz	Megahertz
MIB	Management Information Base
Mod	Modulator or Modulated
MPEG	Moving Pictures Experts Group
ms or msec	Millisecond
M&C	Monitor and Control
N	
NC	Normally Closed
NO	Normally Open
ns	Nanoseconds
NVRAM	Non-Volatile Random Access Memory
N/C	No Connection or Not Connected
O	
OQPSK	Offset Quadrature Phase Shift Keying
P	
PC	Personal Computer
PD Buffer	Plesiochronous/ Doppler Buffer
PLL	Phase Locked Loop
ppb	Parts per Billion
ppm	Parts per Million
P/N	Part Number
Q	
QAM	Quadrature Amplitude Modulation
QPSK	Quadrature Phase Shift Keying
R	
RAM	Random Access Memory

RF	Radio Frequency
ROM	Read Only Memory
rms	Root Mean Square
RU	Rack Unit. 1 RU = 1.75"/4.45 cm
Rx	Receive (Receiver)
RxD	Receive Data
R-S	Reed-Solomon Coding. Reed-Solomon codes are block-based error correcting codes with a wide range of applications in digital communications and storage.
S	
SEQ	Sequential
SYNC	Synchronize
T	
TBD	To Be Designed or To Be Determined
TM	Technical Manual
TPC	Turbo Product Codes
TRE	Trellis
Tx	Transmit (Transmitter)
TxD	Transmit Data
U	
UART	Universal Asynchronous Receiver/Transmitter
UUT	Unit Under Test
V	
V	Volts
VAC	Volts, Alternating Current
VCO	Voltage Controlled Oscillator
VDC	Volts, Direct Current
VIT	Viterbi Decoding
W X Y Z	
W	Watt
Misc.	
μs	Microsecond
Ohms	Ohms
16QAM	16 Quadrature Amplitude Modulation
8PSK	8 Phase Shift Keying
16APSK	16-ary Amplitude and Phase Shift Keying